



THE DESIGN VENUE

Preparatory Design School

CEED 2026 Question Paper

STUDENTS NAME:-----
CONTACT NUMBER:-----
WHATSAPP NUMBER:-----
EMAIL ID:-----

Get Your Answers Analyzed by The Design Venue Mentors in Just 3 Simple Steps!

- 1. Solve the Question Paper**
- 2. Take a Clear Photo of Your Answer Sheet**
- 3. WhatsApp it to: +91 9886452274 or +91 9886034182**
(meet us in person or online for an in-depth analysis!)

For more question papers, tips, and tricks to ace architecture and design entrance exams, visit our website: 

www.thedesignvenue.com

or call us at  **+91 9886452274 | +91 9886034182.**

Let's pave your way to success in design!

Common Entrance Examination for Design

CEED 2026

Question Paper

INSTRUCTIONS

1. The total duration of the examination is 3 hours. The question paper contains two parts - Part A and Part B. The duration of Part A is one hour. The duration of Part B is two hours. Part B will start only after Part A ends. Part A cannot be attempted once Part B commences.
2. Questions of Part A and Part B will appear on the computer. Answers to **Part A** have to be entered in the **computer**. Answers to **Part B** need to be given in the **answer booklet** provided by the invigilator.
3. Part A carries a total of 150 marks. It contains 3 sections. All questions are mandatory. The following table summarises the marking scheme of Part A:

Part A Section	Type of questions	Number of questions	Marks for each correct answer	Marks for each wrong answer	Marks for each question not attempted	Total marks for the section
I	Numerical Answer Type (NAT)	8	4	0	0	32
II	Multiple Select Question (MSQ)	10	Partial Marking	-1	0	40
III	Multiple Choice Question (MCQ)	26	3	-0.5	0	78

4. For each NAT question, the answer is a **number**. The answer needs to be entered using the virtual keyboard on the monitor. No choices will be shown for these questions. In NATs, the correct answer will be awarded **4 marks**. There is no negative or partial marking for NATs.
5. Each MSQ has four choices of which **one or more** is/are the correct answer(s).

The following is the marking scheme:

Full Marks : + 4 If only (all) the correct option(s) is(are) chosen and NONE of the incorrect options is chosen

Partial Marks : + 3 If all the four options are correct but ONLY three options are chosen

Partial Marks : + 2 If three or more options are correct but ONLY two options are chosen, both of which are correct and NONE of the incorrect options is chosen

Partial Marks : + 1 *If two or more options are correct but ONLY one option is chosen and it is a correct option and NONE of the incorrect options is chosen*

Zero Marks : 0 *If none of the options is chosen (i.e. the question is unanswered)*

Negative Marks: -1 *In all other cases*

6. Each MCQ has four choices of which **only one** is the correct answer. In MCQs, the correct answer will be awarded **3 marks** and wrong answer will be awarded **-0.5 marks**. Questions not attempted will be awarded zero marks.
7. Scribble pads will be provided for rough work for Part A. These have to be returned to the invigilator at the **end of Part A exam**.
8. Part B carries a total of 100 marks. It contains 5 questions of 20 marks each. **All questions** in Part B are **mandatory**. Each question must be answered on the page(s) designated for that question in the answer booklet. Additional instructions to Part B questions are provided in the answer booklet.
9. In Part B, colour pencils, crayons, sketch pens etc. may be used unless otherwise specified in the questions.
10. Calculators, charts, graph-sheets, mathematical tables, mobile phone, watches of any type and other electronic gadgets are **NOT** allowed in the examination hall.

Part A – Section I: Numerical Answer Type Questions

- Q.01** Five geometric blocks with their dimensions are given below. Calculate the length of the path as shown in the image below, between points A and B.

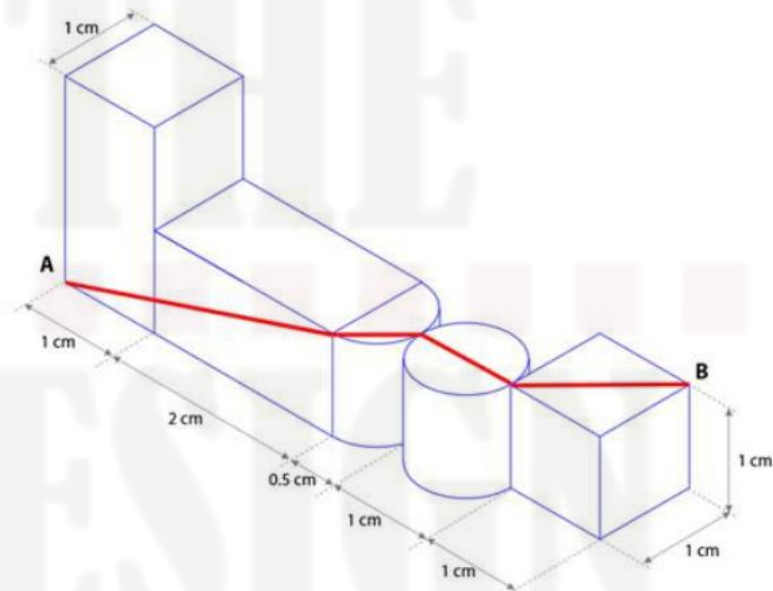

- Q.02** Shown below is an ice-cream cone completely filled with ice-cream. Assume the top portion (visible portion of ice-cream) is a perfect hemisphere. What is the total mass of the ice-cream in grams? The density of ice-cream = 0.9 grams/cubic centimeter. Consider the value of $\pi = 3.14$.

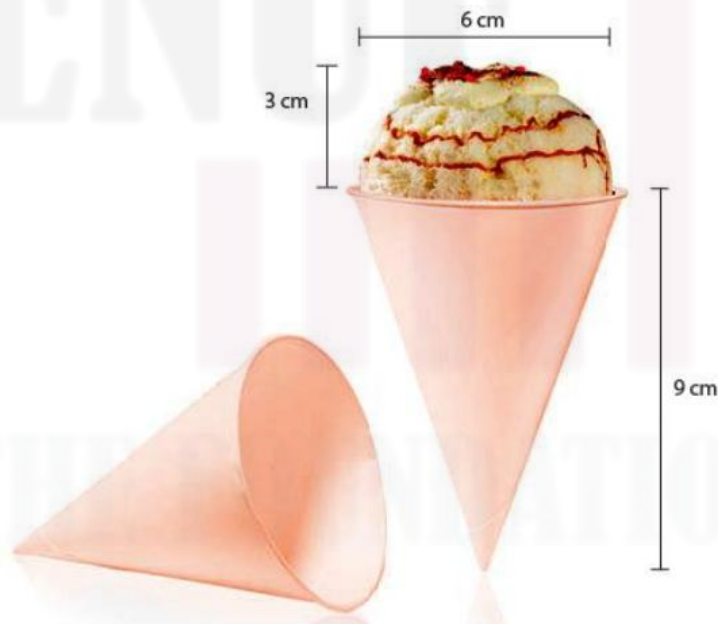

Q.03 A square paper of side 10 cm is folded sequentially and a circular cut of radius 1 cm is made at the corners as shown below. After unfolding the sheet completely, what will be the total area of all the pieces which have been cut-out from the original square sheet? Assume the value of $\pi = 3.14$.

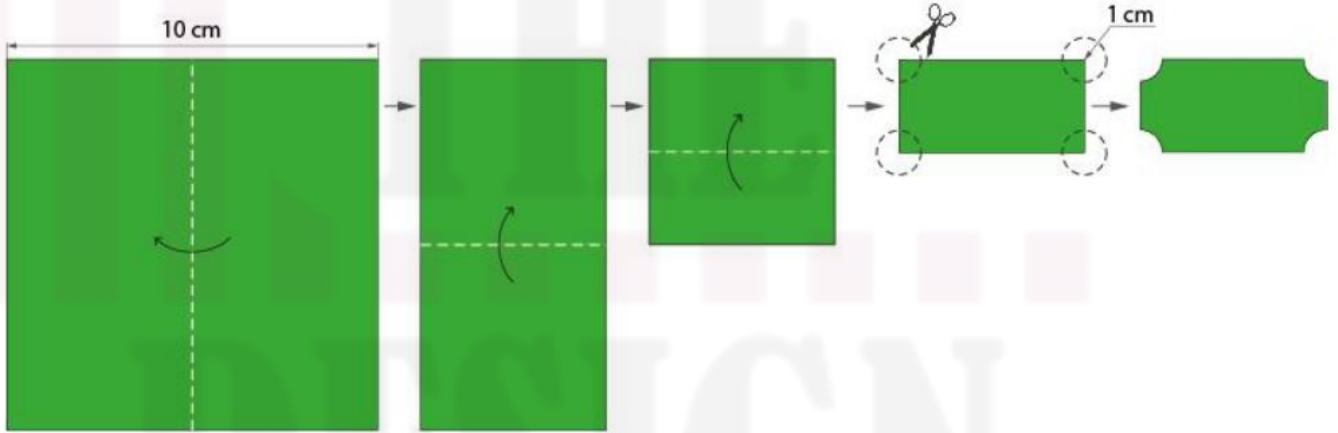

Q.04 How many unique patterns are there in the image?

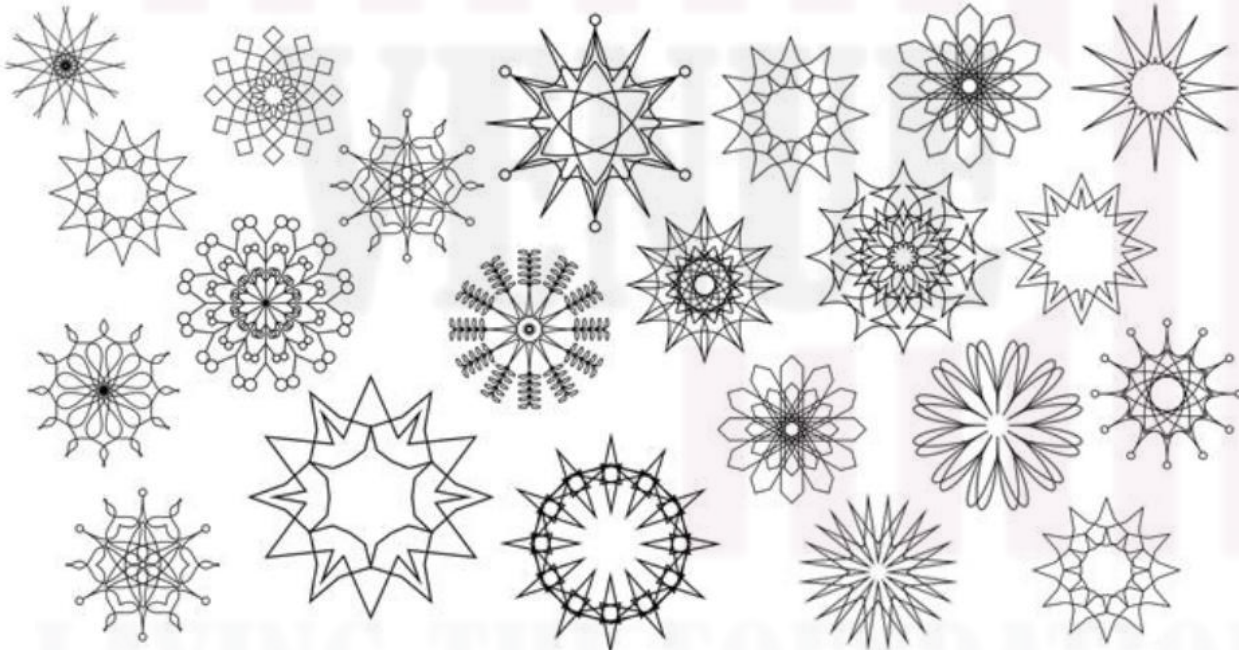

Q.05 How many spheres are rotating in the space shown below?

[This question contains an animated GIF image.]



Q.06 Nine tiles containing parts of English letters in different Text Fonts, are shown below. What is the maximum number of COMPLETE letters that can be formed, by rearranging the tiles in a 3x3 grid?



Q.07 A plane passes through three vertices of a cube and divides the cube into two parts, a green part and a blue part, and they remain together, as shown below. Eight such cubes are assembled to create a larger cube, where blue portion is on the inside as shown on the right. Calculate the volume of blue part in the larger cube, if the edge of the original cube is 1 cm.

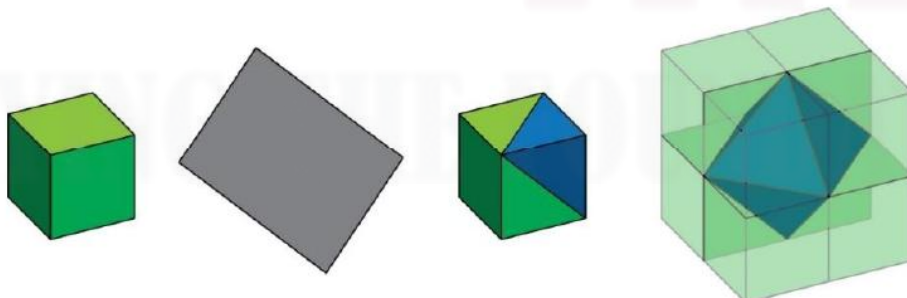

Q.08 A board game, and two views of a unique dice are shown below. This unique dice has only three faces with numbers one, two and three. Consider all the ladders are advantages that allow the player to jump from initial to final point. What is the minimum number of dice throws that is required to move from Point A to Point B using all given advantages on the board?

41	42	43	44	45	46	47	48	49	50
40	39	38	37	36	35	34	33	32	31
21	22	23	24	25	26	27	28	29	30
20	19	18	17	16	15	14	13	12	11
1	2	3	4	5	6	7	8	9	10

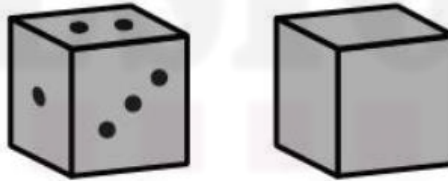

Part A – Section II: Multiple Select Questions

Q.9 A coloured sheet is folded into an octahedron as shown on the left. Which of the options show(s) the CORRECT rotated views of the octahedron?

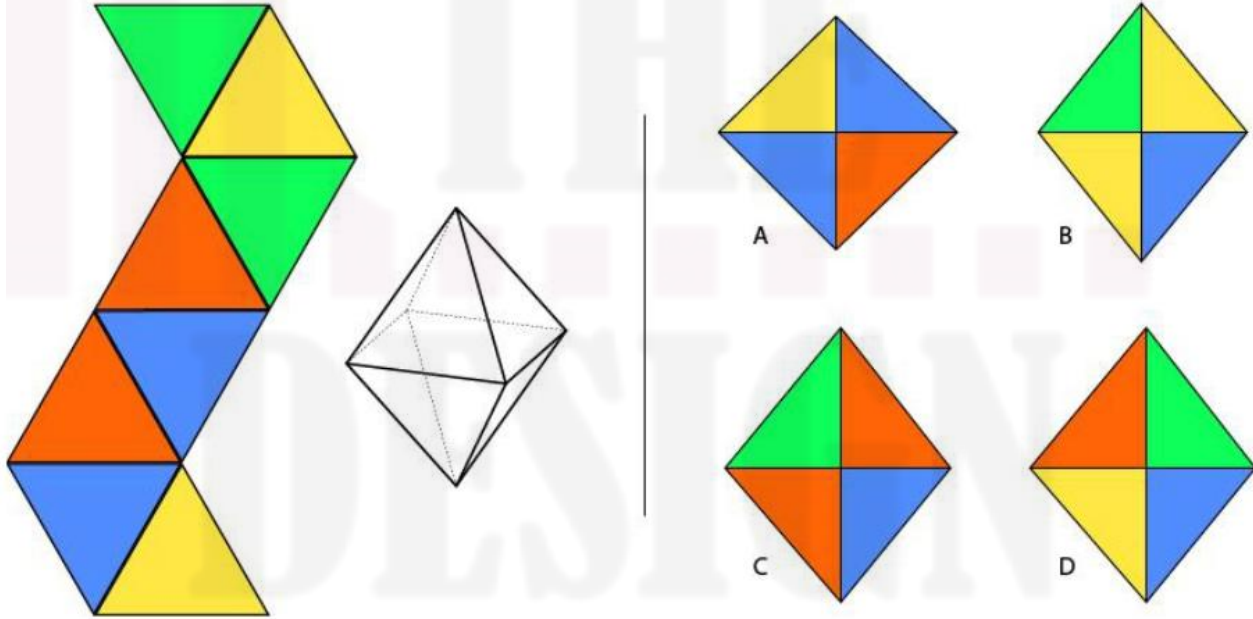

Q.10 Which option(s) is/are NOT a part of the image on the left?



Q.11 Four objects that are symmetrical along vertical planes are placed in four containers in the orientation shown below. Molten wax is poured in each of these containers up to the level indicated on the objects. Assuming that wax does not stick to the objects, which of the objects will leave its exact negative impression on the set wax when they are vertically lifted?

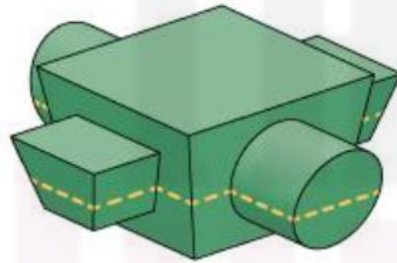

A

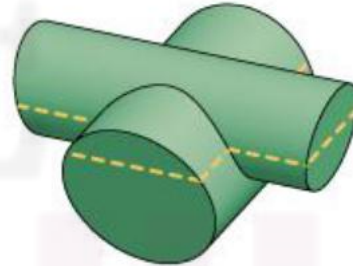

B

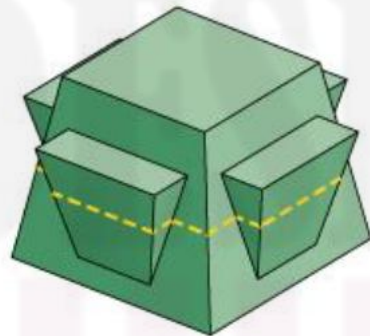

C

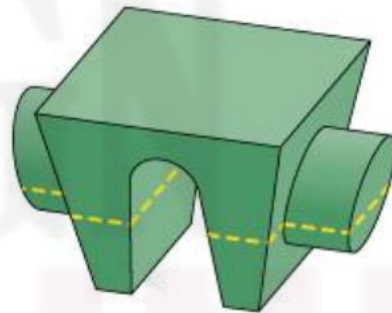

D

Q.12 Coloured strips are printed on a transparent sheet as shown below. The bottom half of this sheet is folded backwards along the PQ axis to form a semi-circle. Which of the option(s) will be a part of the resultant semi-circle?



A



B



C



D

Q.13 A table made out of cardboard is shown on left. If dotted lines indicate folding, which of the option(s) is/are the unfolded view(s) of the table?

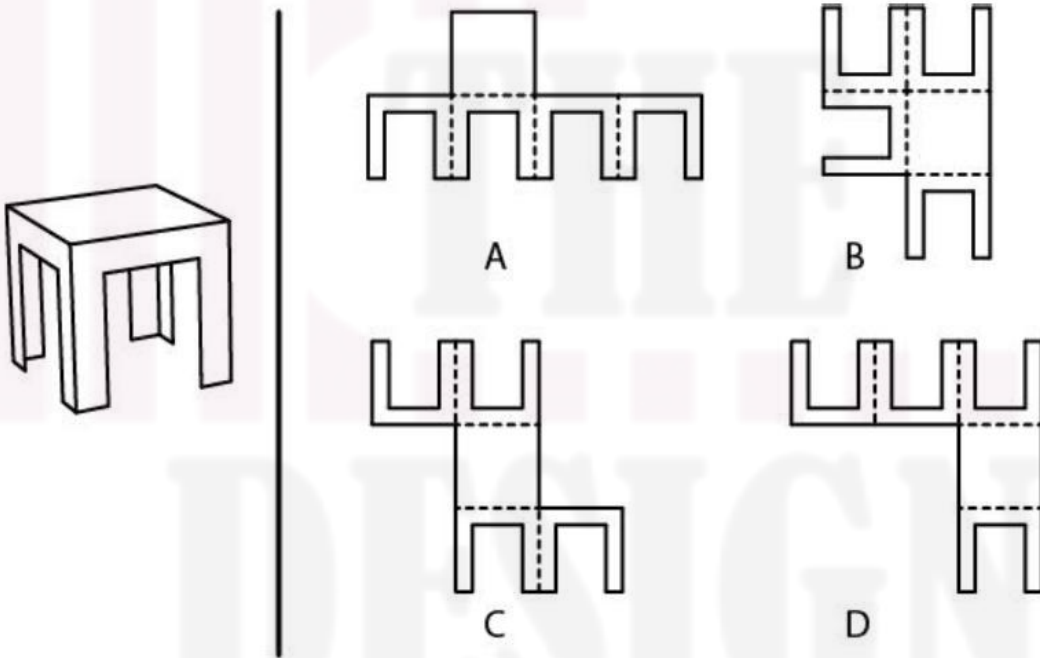

Q.14 A plant pruner (cutter) with two studs P and Q are shown on the left in open and closed positions. Which option(s) will allow the pruner to return to its open position?



Q.15 A solid object with triangular groove is shown on the left. Which option(s) along with this object can form the combination shown on the right?

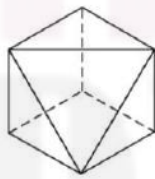
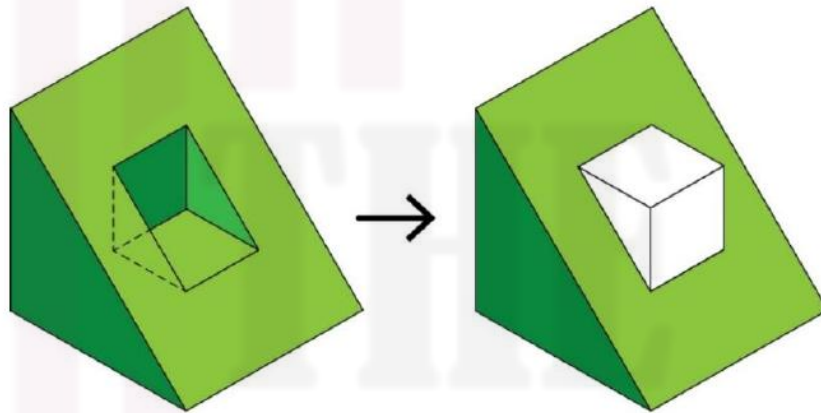

A

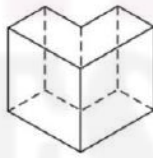

B

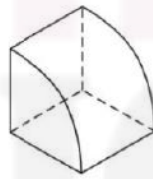

C



D

Q.16 An animation of four planets orbiting around the sun is shown below. Based on this animation, which of the following statement(s) is/are TRUE?

[This question contains an animated GIF image.]

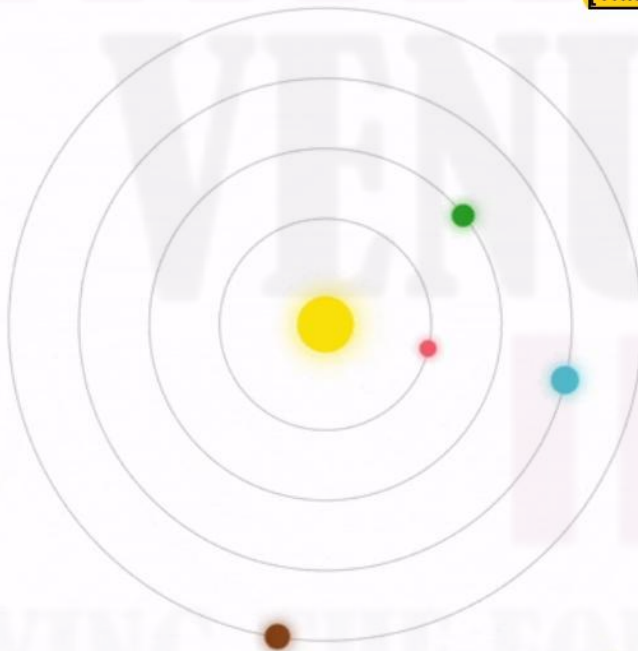

- A. When Planet Blue completes 2 orbits, Planet Green will complete 1 orbit.
- B. When Planet Blue completes 3 orbits, Planet Brown will complete 2 orbits.
- C. When Planet Green completes 1 orbit, Planet Red will complete 2 orbits.
- D. When Planet Red completes 4 orbits, Planet Brown will complete 2 orbits.

Q.17 Two views of a 3D object are shown on the left. Which of the option(s) is/are the same object?

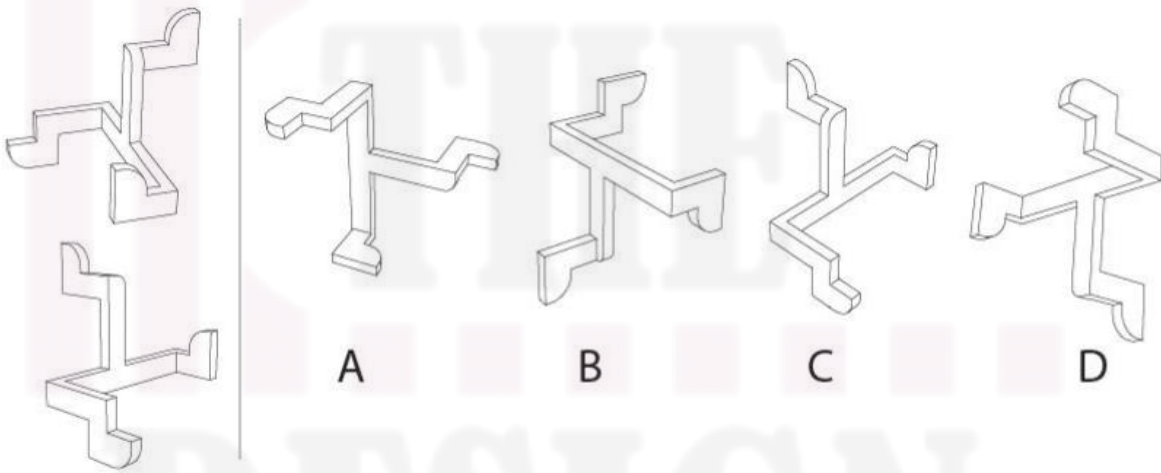

Q.18 Six different shapes are cut from a square as shown on the left. Which option(s) is/are made using only the cut pieces? Pieces can be rotated and not all pieces need to be used.

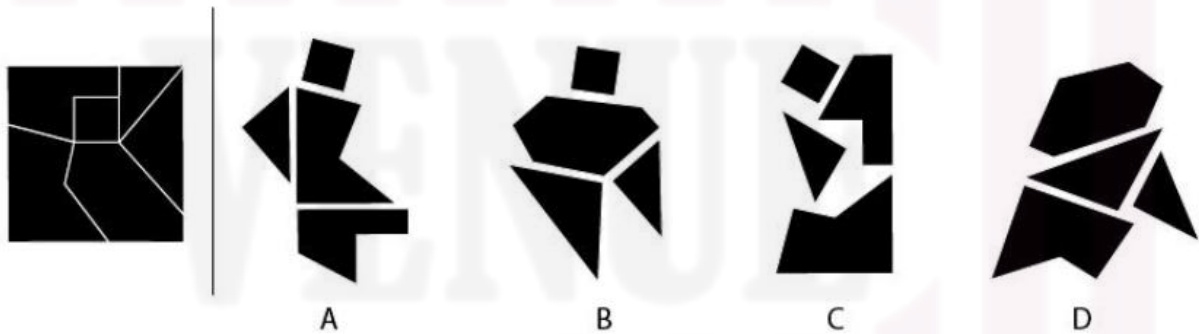

Part A – Section III: Multiple Choice Questions

Q.19 Three views of a stack of sugar cubes are shown below. What is the MINIMUM number of cubes that are required to produce this stack?

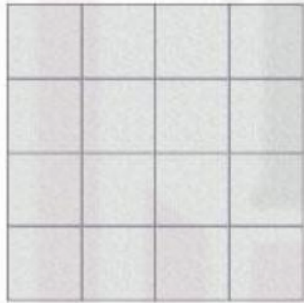

Top View

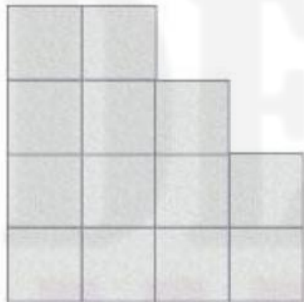

Front View

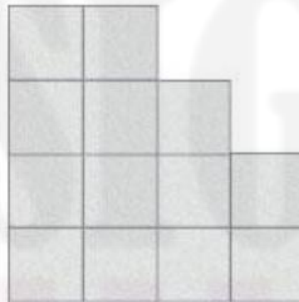

Side View

- A. 25
- B. 28
- C. 31
- D. 35

Q.20 A hard rubber roller is cut with a 'V-shaped' profile at three locations as shown in the Top View in the image on the left. The roller is then dipped in blue colour and rolled over a white plane. Which option shows the correct impression on the plane?

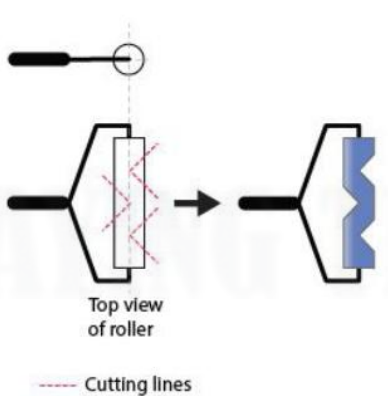

A

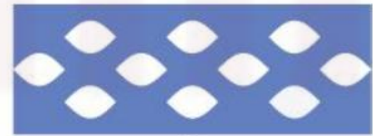

B



C



D

Q.21 P and Q are printed patterns where the white portion of both the patterns is transparent. If Q is overlapped on P, what will be the resultant image?

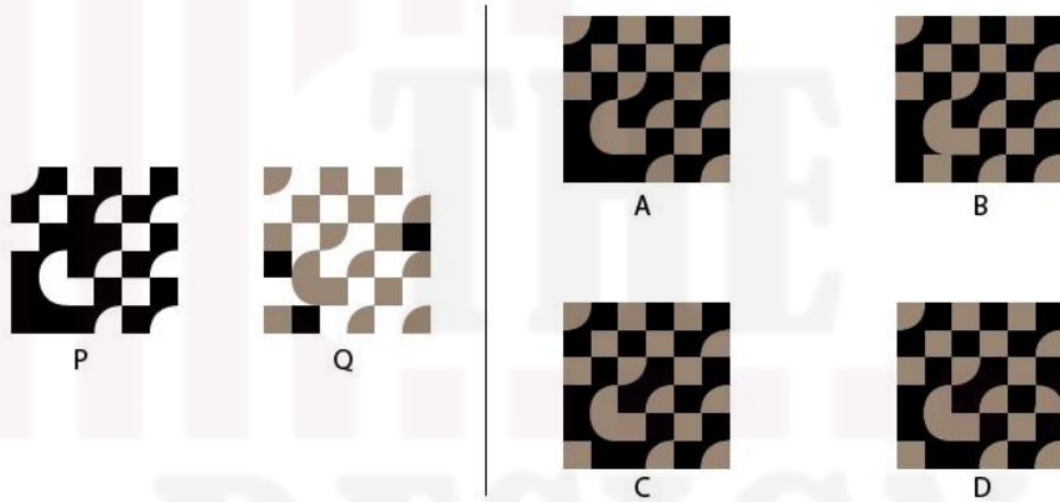

Q 22 Four words written in a particular font are given below. Which of the options belong to the same font?

বুলবুল পাখি ময়না টিয়ে

আদ আদ আদ আদ
 A B C D

Q.23 Which spanner from the options will fit the maximum number of nuts shown on the left?

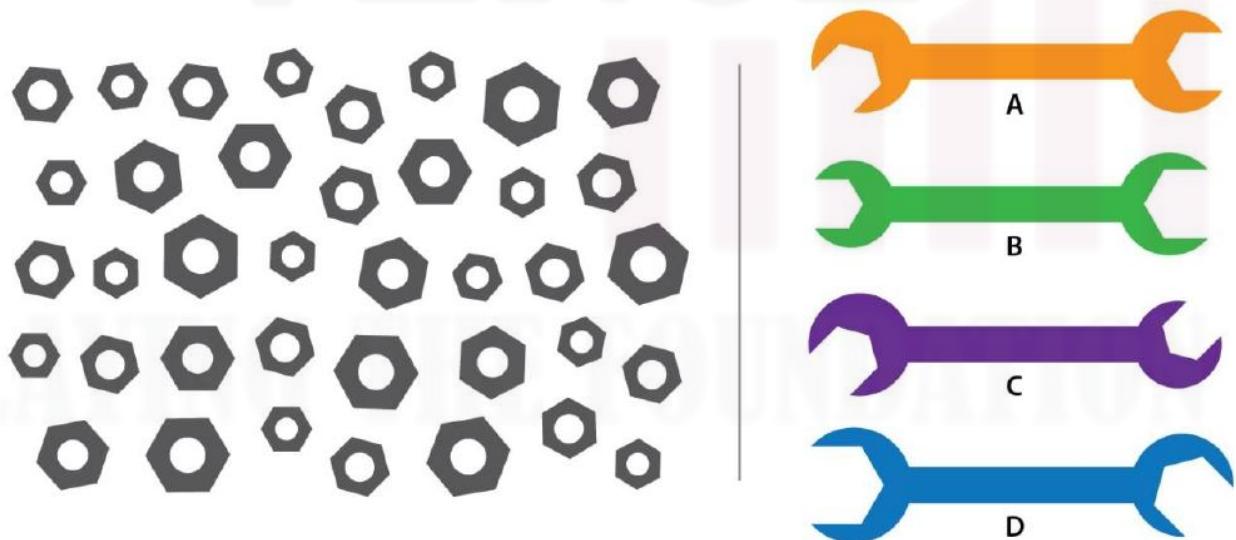

Q.24 Which option shows the correct perspective drawing of the object when it is viewed from the direction as shown on the left?

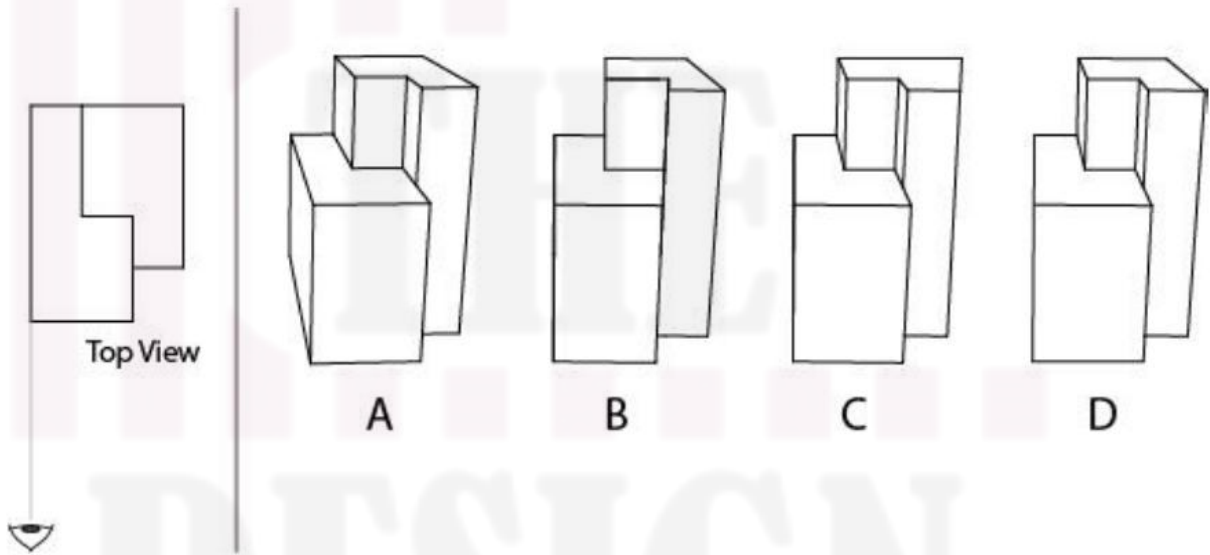

Q.25 A red dot is connected with two non-elastic strings P and Q of equal length. The strings are fixed at points 1 and 2, as shown below. Consider both the strings, points 1, 2, and the red dot are all on the same plane throughout the operations. If one of the strings is fully stretched (taut) at all times, what will be the shape of the path traced by the dot?

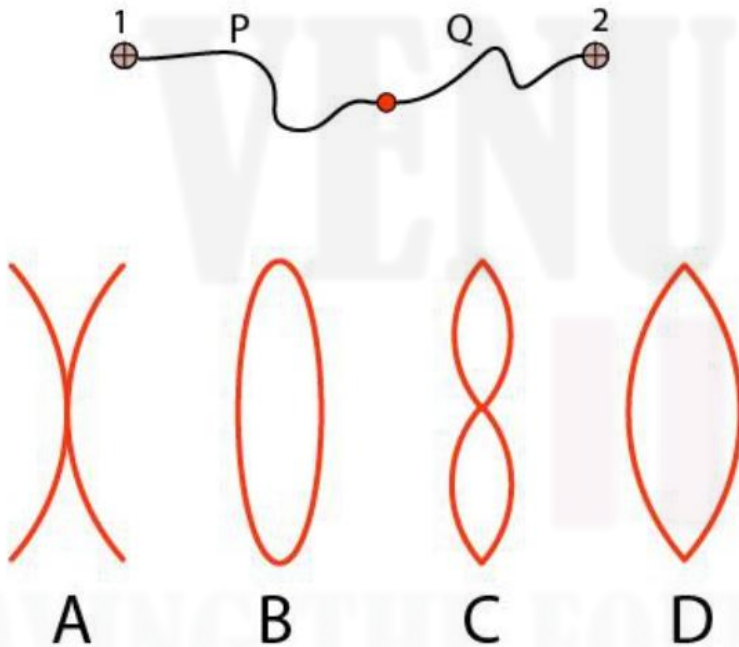

Q.26 Which option will replace the question mark?

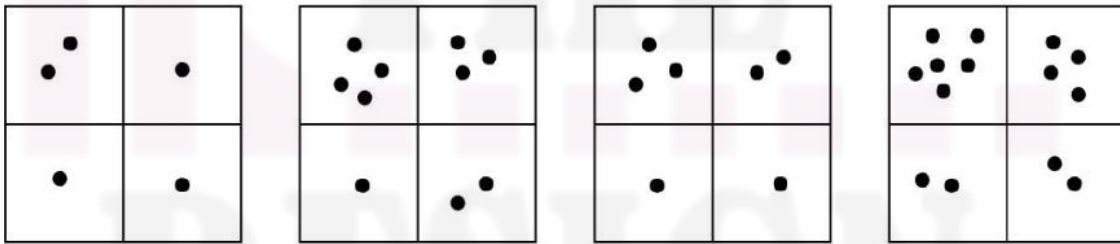
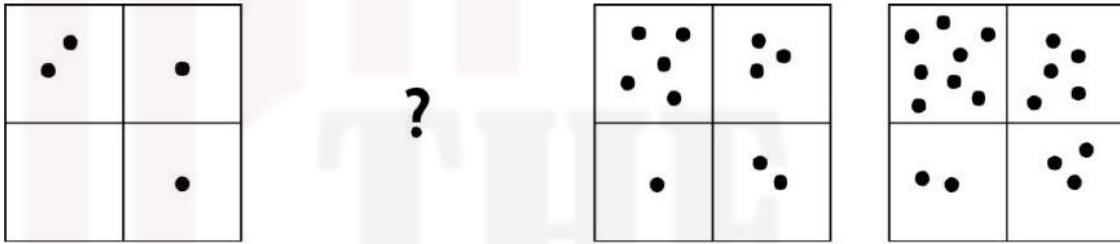

A

B

C

D

Q.27 A grid PQRS is distorted such that its edges get stretched or compressed UNIFORMLY to form P'Q'R'S' as shown on the left. Identify the correct distorted grid from the options.

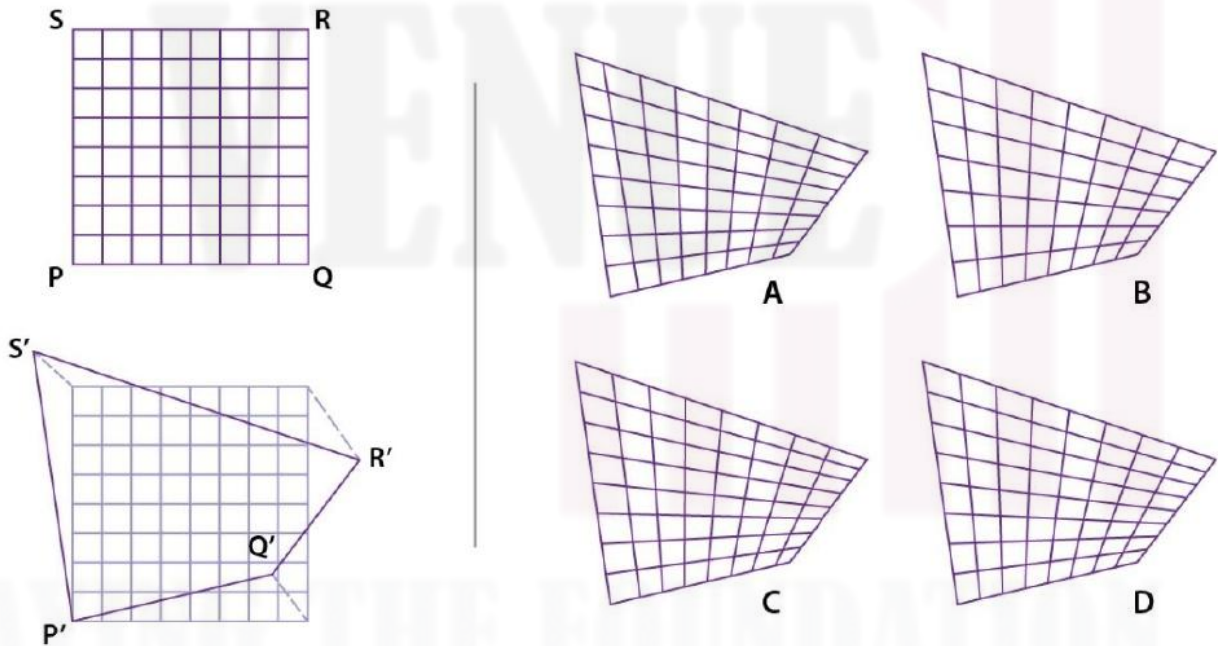

Q.28 Sets of Toys and Furniture are shown below. Which option correctly matches the furniture and toys, based on similar product features?



P



Q



R



S



I



II



III



IV

- A. P-I, Q-II, R-IV, S-III
- B. P-II, Q-I, R-III, S-IV
- C. P-III, Q-II, R-IV, S-I
- D. P-III, Q-I, R-IV, S-II

Q.29 Select the CORRECT option that names the art movements sequentially from left to right.



- A. De Stijl, Impressionism, Pop Art, Art Nouveau, Baroque
- B. De Stijl, Impressionism, Pop Art, Baroque, Art Nouveau
- C. Pop Art, Baroque, De Stijl, Impressionism, Art Nouveau
- D. De Stijl, Art Nouveau, Pop Art, Impressionism, Baroque

Q.30 Choose the CORRECT option that combines with the image on the left to form a word from the English language.

Clairvoyance

A Clairvoyance

B Clairvoyance

C Clairvoyance

D Clairvoyance

Q.31 "OPEN HEART" is printed on a folded paper as shown below. Identify the CORRECT option when the paper is unfolded and seen from the other side.

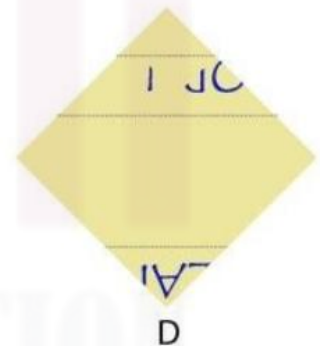
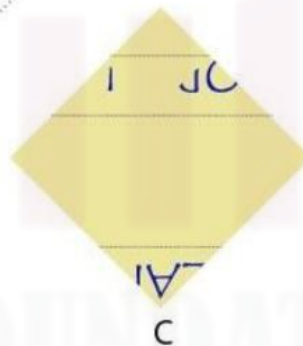
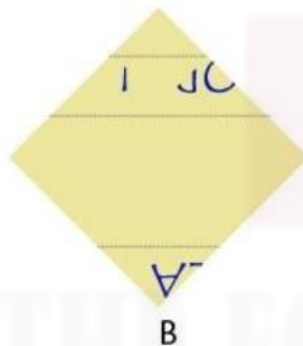
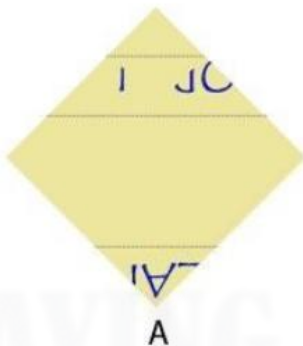

Q.32 Several magnetic and non-magnetic bars of equal dimensions are glued together as shown on the left. If blue denotes magnetic north, red denotes magnetic south and grey denotes non-magnetic material, what will be the configuration of the faces on the other end?

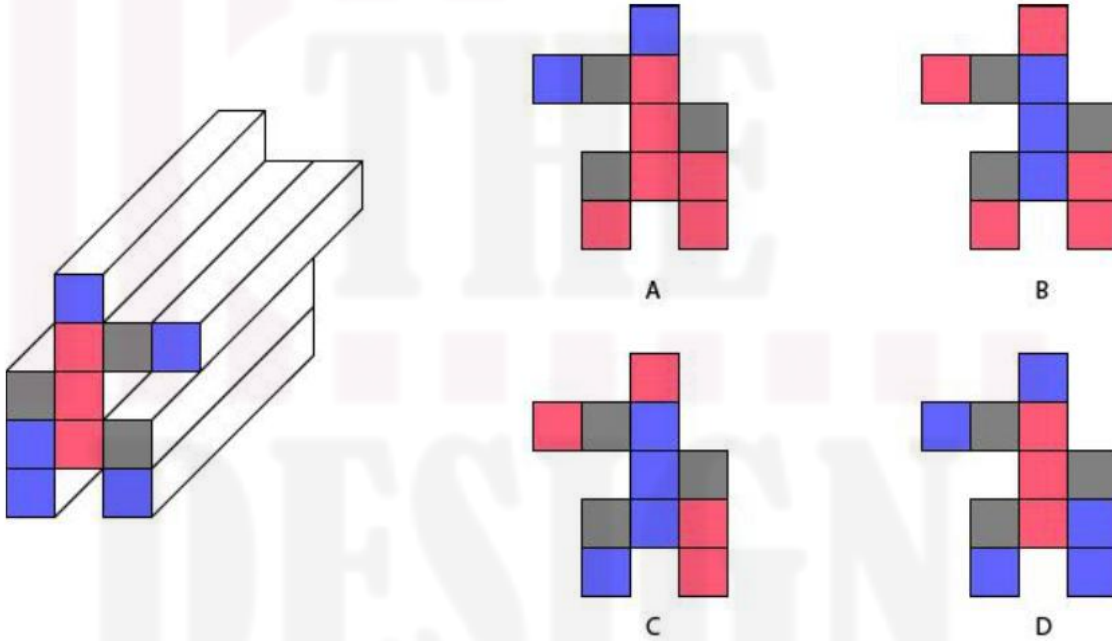

Q.33 Which option will replace the question mark?

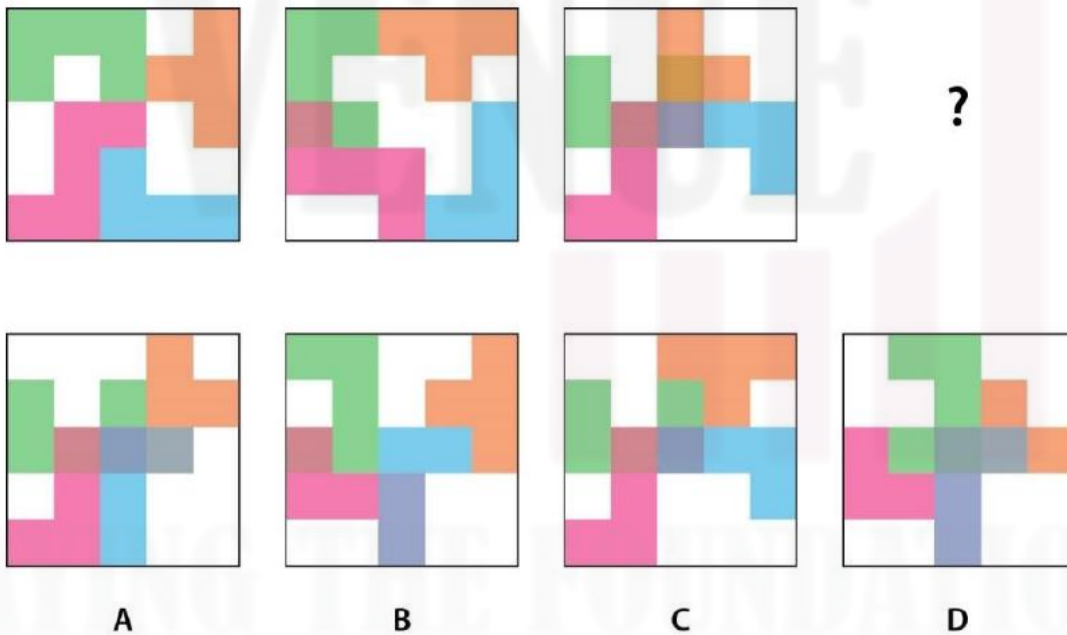

Q.34 A toy is shown on the left. When the wheels of this toy rotate, the fan is also required to spin. If one pair of gears is to be used exclusively, which option will make this possible?

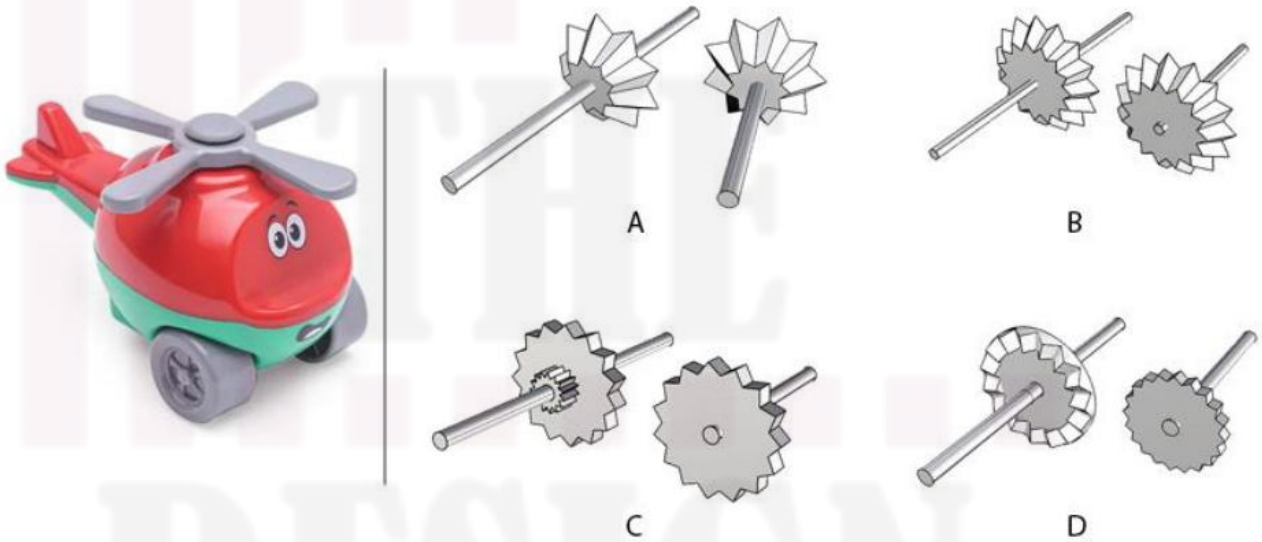

Q.35 A toy with reciprocating movement is shown. As the wheels of the toy rotate, the head is required to reciprocate. If given options are indicative of conversion of rotary to linear motion using a disc located at the centre of the wheel shaft, which option will result in the required movement when the toy is pushed forward? Assume a working spring loaded cam mechanism in the relevant option/s.

[This question contains an animated GIF image.]

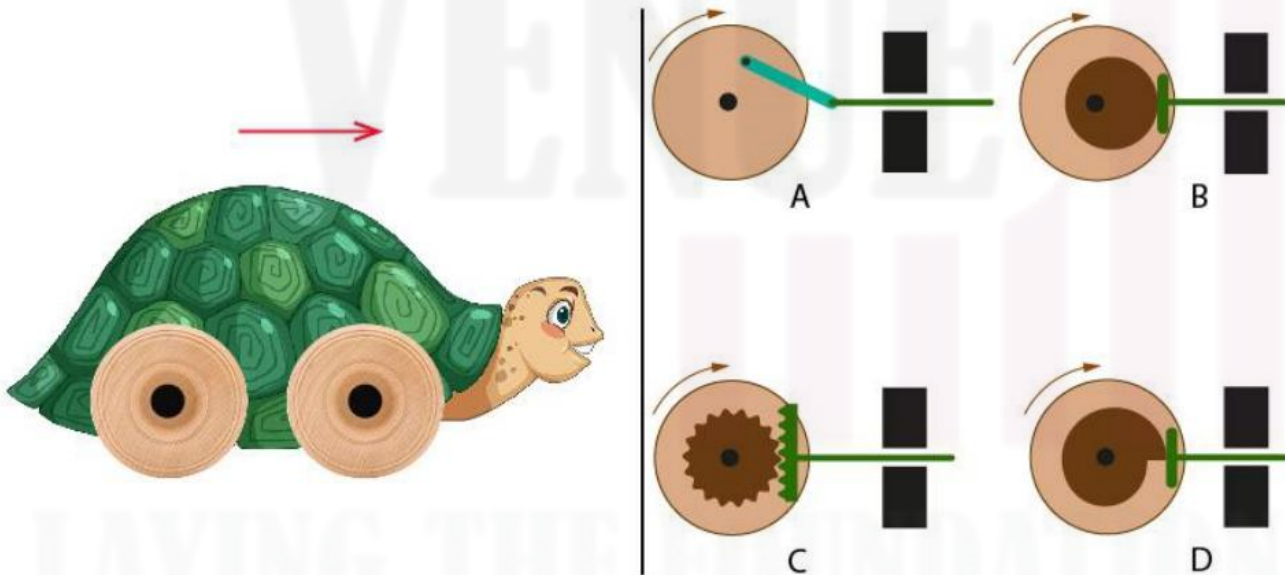

Q.36 Select the correct order of the monuments in India from North to South, as shown below.



P



Q



R



S



T



U

- A. S, R, P, U, T, Q
- B. R, S, U, Q, P, T
- C. S, R, Q, U, P, T
- D. R, S, Q, T, U, P

Q.37 Various designs of an application screen are shown below. Identify the screen that INCORRECTLY depicts functions of standard interface components.



A



B



C



D

Q.38 A wooden artifact made using traditional tools and processes is shown below. Which option shows the relevant operations involved in its making, not necessarily in the actual production sequence?

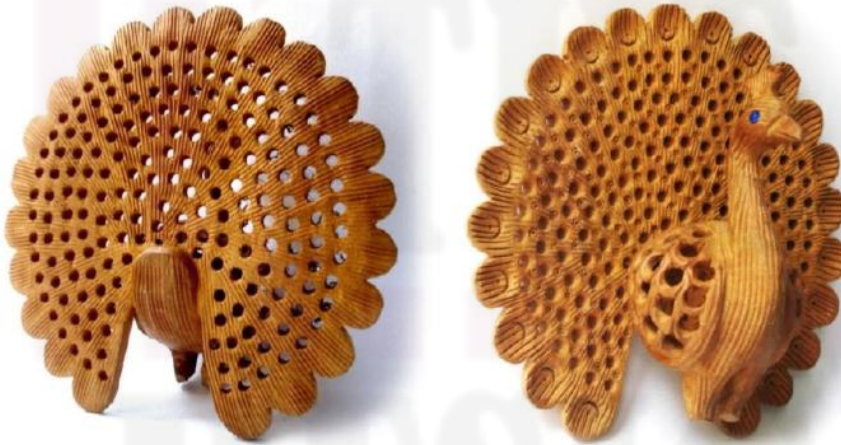

- A. Drilling, Chiselling, Forming, Cutting
- B. Chiselling, Milling, Punching, Forming
- C. Drilling, Powder Coating, Chiselling, Cutting
- D. Finishing, Sanding, Drilling, Chiselling

Q.39 A seat is to be designed for a public bus for adult Indian population. While designing, which option needs to be considered so that MOST of the relevant category population can sit on it comfortably?

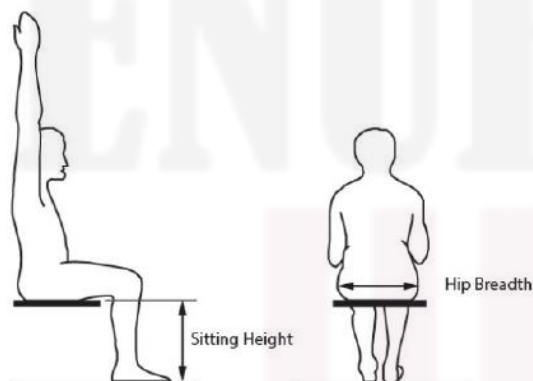

- A. Seat height is 95th percentile of sitting height and seat breadth is 5th percentile of hip breadth of adult population.
- B. Seat height is 50th percentile of sitting height and seat breadth is 95th percentile of hip breadth of adult population.
- C. Seat height is 5th percentile of sitting height and seat breadth is 5th percentile of hip breadth of adult population.
- D. Seat height is 50th percentile of sitting height and seat breadth is 5th percentile of hip breadth of adult population.

Q.40 Perspective view of two identical hollow cylinders is shown below. Assume the outer diameter and length of each cylinder are equal. The two cylinders intersect each other at 90 degrees to form a union, such that their centroids (centre of axis) coincide. How many visible surfaces will the resultant union have?



- A. 24
- B. 32
- C. 28
- D. 20

Q.41 Isometric view of a solid copper object is shown below. If a constant heat source of 100 degrees C is applied at the point P continuously, which point on the solid will reach the temperature of the heat source the earliest? Neglect heat losses and assume point P lies on an equilateral triangle.

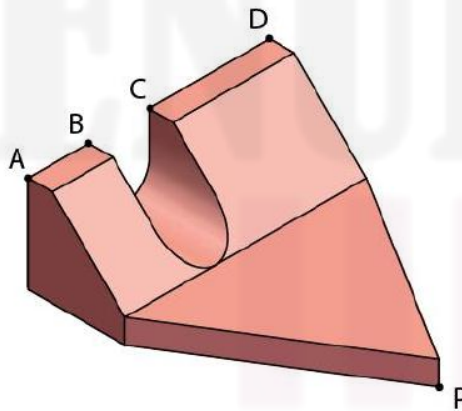

- A
- B
- C
- D

Q.42 A hollow cylinder is lit by sunlight at 45 degrees as shown on the left. If seen from a fixed point, which option is the closest representation of the lit area inside the cylinder?

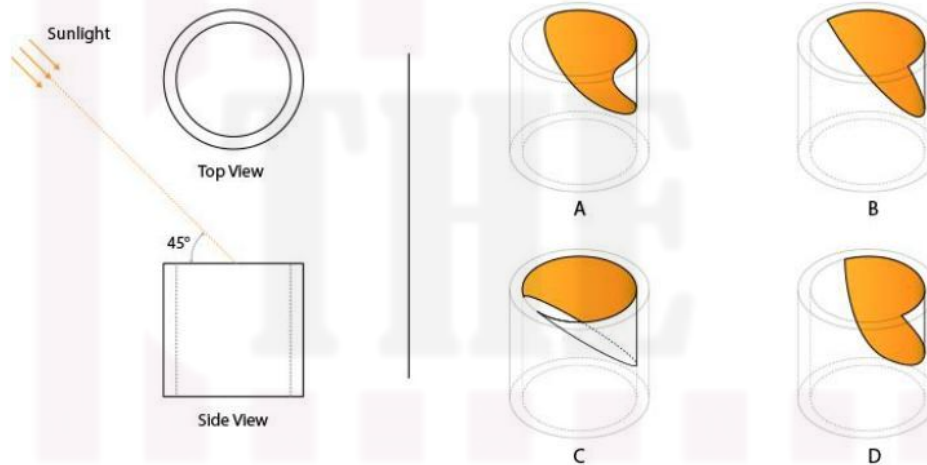

Q.43 Two objects created using a toy set are shown below. Choose the set of features that CANNOT be attributed to the toy set.



- A. Use of slotted plates, sheets and brackets; Use of Standardized components.
- B. Possibility of multiple combinations; Appropriate for pre-school kids.
- C. Suitable for Creativity and Spatial development; Suitable for prototyping.
- D. Appropriate for learning through play; Suitable for making study models.

Q.44 Select the option that shows the CORRECT sequence of gestalt principles associated with the image, as seen from the left to right.

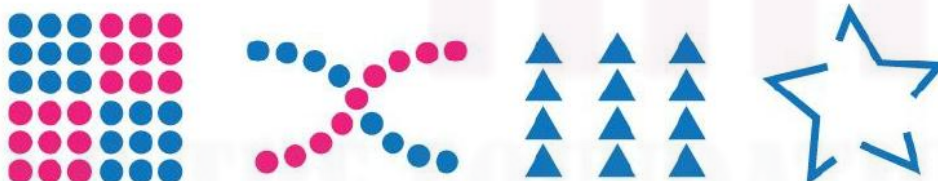

- A. Closure, Proximity, Continuity, Similarity
- B. Similarity, Continuity, Proximity, Closure
- C. Continuity, Similarity, Closure, Proximity
- D. Proximity, Closure, Similarity, Continuity

Part B

All questions are mandatory

Q.1 Sketching: Mandatory question (20 marks)

One afternoon, seven years old Chinu and her pet dog are enjoying snacks in their kitchen. Chinu's father suddenly enters the kitchen and sees this pleasant moment with a smile.

Sketch the whole scene from the point of view of a chair kept nearby.

Additional Instructions:

- Use only black/HB-series pencils
- Do not use other colours
- Draw only in the given space

Evaluation Criteria:

- Character and Expressions
- Proportion and Composition
- Quality of Sketching
- Environment and Props

Q.2 Creativity: Mandatory question (20 marks)

In the given frames, sketch a story by incorporating the symbols shown below. Follow these instructions:

- Give an appropriate title to the story.
- Use ANY TWO symbols in each frame; Use each symbol ONLY ONCE in the whole story.
- The symbols cannot be modified, but can be rotated, flipped or scaled proportionately.
- You are free to sketch additional elements (backgrounds, characters, props etc.) to make the story meaningful.
- Label the frames in the bottom left corners with the number 1,2,3, and 4 to indicate the sequence of your story.



Evaluation criteria:

- Originality
- Graphical Narrative (Story Communication)
- Humour and Surprise
- Clarity and Neatness of Sketches

Q.3 Visual sensitivity: Mandatory question (20 marks = 4 x 5 marks)

A new museum with the theme “Indian Museum of Science” is being set up, which will cater primarily to Indian visitors. Create four icons based on the museum theme, to communicate the following sections to visitors:

- Robotics
- Energy Science
- Ocean Science
- Food Technology

All icons should be clear and visible, and have a consistent visual language. Draw the icons in the FOUR squares provided in the answer booklet. Icons should only have visuals. DO NOT use text. Only BLACK & WHITE colours should be used for the icons.

Evaluation Criteria:

- Consistency of visual language
- Thematic appropriateness
- Effective communication
- Composition, Clarity and Neatness

Q.4 Form sensitivity: Mandatory question (20 marks)

Conceptualise and render a usable single seat furniture that is inspired by a sphere, for a living room. The sphere may be modified by cutting, adding, subtracting, deforming and repeating. However, the essence of the sphere should be retained.

Evaluation Criteria:

- Uniqueness of the form
- Form-Function relevance and relationship
- Detailing
- Rendering quality

Q.5 Problem identification: Mandatory question (20 marks)

An elderly couple from Srinagar is travelling to Chennai for medical treatment. They will travel by train for most of their journey and plan to take a bus and auto rickshaws for all local commutes.

Imagine their journey and identify FOUR distinct problems that they might face, which may need design solutions.

Write the FOUR problems statements starting with the words "How can we..." for the given context, in the space provided on the answer booklet. (2 x 4 = 8 marks)

For your reference, an example of "How can we ..." from another context: How can we - make science learning enjoyable for primary school children?

Select any ONE of the four identified problems statements. Draw TWO potential design solutions for the selected problem statement in the boxes provided on the answer booklet. Write a short title for each solution in the space provided inside the box. (6 x 2 = 12 marks)

Evaluation Criteria:

- Variety and uniqueness of the problems
- Relevance of the problems
- Practical feasibility of the design solutions
- Clarity in communication

The Design Venue:

Your Gateway to Design Excellence!



**THE
DESIGN
VENUE**

PIONEERS IN NID, NIFT, U/CEED & NATA COACHING

Turn your design dreams into reality with expert guidance from industry leaders.

Contact Now



+91 9886452274



THEDESIGNVENUE.COM

Join TODAY