



# THE DESIGN VENUE

---

## Preparatory Design School

### CEED 2025 Question Paper

STUDENTS NAME:-----  
CONTACT NUMBER:-----  
WHATSAPP NUMBER:-----  
EMAIL ID:-----

**Get Your Answers Analyzed by The Design Venue Mentors in Just 3 Simple Steps!**

- 1. Solve the Question Paper**
- 2. Take a Clear Photo of Your Answer Sheet**
- 3. WhatsApp it to: +91 9886452274 or +91 9886034182**  
(meet us in person or online for an in-depth analysis!)

For more question papers, tips, and tricks to ace architecture and design entrance exams, visit our website: 

**[www.thedesignvenue.com](http://www.thedesignvenue.com)**

or call us at  **+91 9886452274 | +91 9886034182.**

***Let's pave your way to success in design!***

**Common Entrance Examination for Design**

**CEED 2025**

**Question Paper**

## INSTRUCTIONS

1. The total duration of the examination is 3 hours. The question paper contains two parts - Part A and Part B. The duration of Part A is one hour. The duration of Part B is two hours. Part B will start only after Part A ends. Part A cannot be attempted once Part B commences.
2. Questions of Part A and Part B will appear on the computer. Answers to **Part A** have to be entered in the **computer**. Answers to **Part B** need to be given in the **answer booklet** provided by the invigilator.
3. Part A carries a total of 150 marks. It contains 3 sections. All questions are mandatory. The following table summarises the marking scheme of Part A:

Part A Section	Type of questions	Number of questions	Marks for each correct answer	Marks for each wrong answer	Marks for each question not attempted	Total marks for the section
I	Numerical Answer Type (NAT)	8	4	0	0	32
II	Multiple Select Question (MSQ)	10	Partial Marking	-1	0	40
III	Multiple Choice Question (MCQ)	26	3	-0.5	0	78

4. For each NAT question, the answer is a **number**. The answer needs to be entered using the virtual keyboard on the monitor. No choices will be shown for these questions. In NATs, the correct answer will be awarded **4 marks**. There is no negative or partial marking for NATs.
5. Each MSQ has four choices of which **one or more** is/are the correct answer(s).

The following is the marking scheme:

**Full Marks : + 4** If only (all) the correct option(s) is(are) chosen and NONE of the incorrect options is chosen

**Partial Marks : + 3** If all the four options are correct but ONLY three options are chosen

**Partial Marks : + 2** If three or more options are correct but ONLY two options are chosen, both of which are correct and NONE of the incorrect options is chosen

**Partial Marks : + 1** If two or more options are correct but ONLY one option is chosen and it is a correct option and NONE of the incorrect options is chosen

**Zero Marks : 0** If none of the options is chosen (i.e. the question is unanswered)

**Negative Marks: -1** In all other cases

6. Each MCQ has four choices of which **only one** is the correct answer. In MCQs, the correct answer will be awarded **3 marks** and wrong answer will be awarded **–0.5 marks**. Questions not attempted will be awarded zero marks.
7. Scribble pads will be provided for rough work for Part A. These have to be returned to the invigilator at the **end of Part A exam**.
8. Part B carries a total of 100 marks. It contains 5 questions of 20 marks each. **All questions** in Part B are **mandatory**. Each question must be answered on the page(s) designated for that question in the answer booklet. Additional instructions to Part B questions are provided in the answer booklet.
9. In Part B, colour pencils, crayons, sketch pens etc. may be used unless otherwise specified in the questions.
10. Calculators, charts, graph-sheets, mathematical tables, mobile phone, watches of any type and other electronic gadgets are **NOT** allowed in the examination hall.

**Part A – Section I: Numerical Answer Type Questions**

**Q.01** The words given below are written using a particular font. Identify the digit that does not belong to the same font?

Electoral Mandate

8 6 0 2  
9 5  
1 4 7 3

**Q.02** Shown below is a cross-section which is revolved 270 degrees around the P-Q axis, to create a solid. How many surfaces will the resultant solid have?



**Q.03** Shown below is a strip of paper which is folded multiple times. How many red pawns are placed on the same side of the paper as the blue pawn?

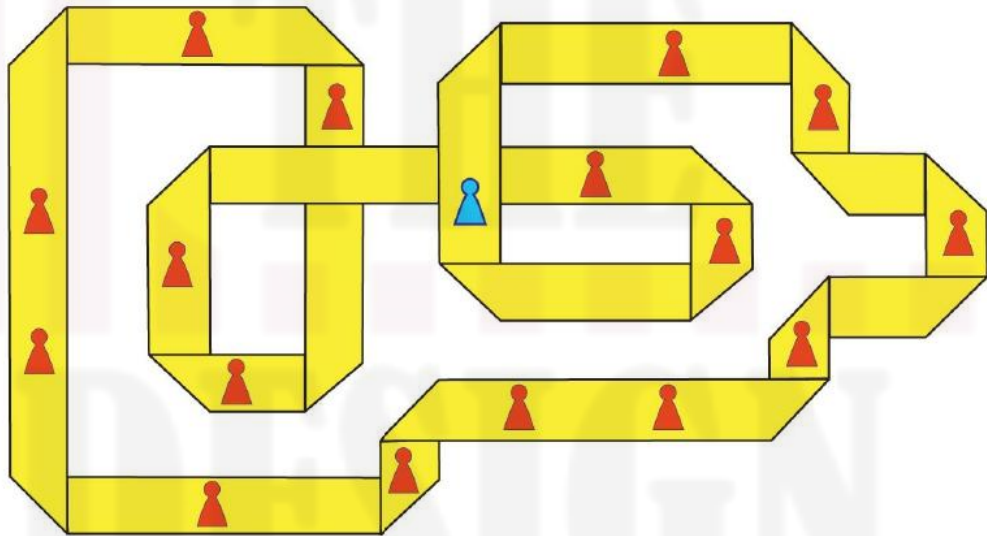

**Q.04** Shown below is an image of multiple footwear items. How many complete pairs are there?



**Q.05** Shown below is a configuration of an isosceles triangle sliced into eight parts, each of the same height. While the first and last parts of the triangle remain fixed, the remaining parts have been displaced horizontally, by multiples of 0.5 cm. What is the area of the grey portion?

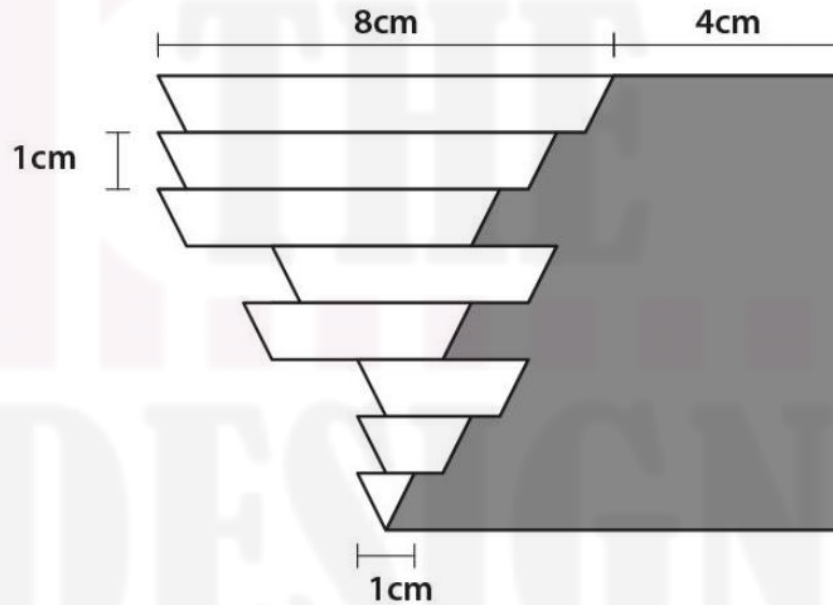

**Q.06** Shown below is an arrangement of closely stacked spheres. Assume each one to be in contact with its immediate neighbour. What is the total number of points where the spheres touch each other?

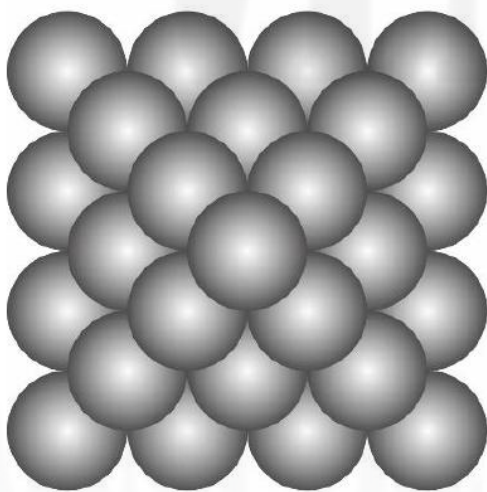

**Top View**

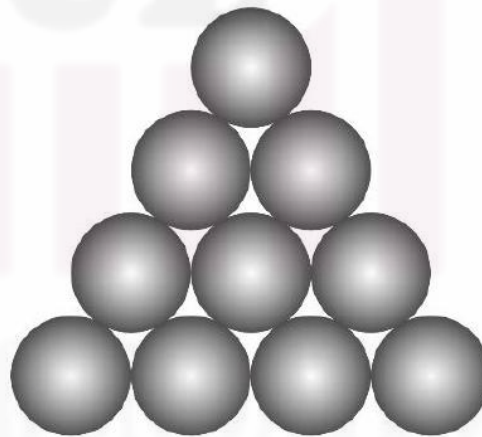

**Elevation / Side view**

**Q.07** Shown below are three perspective views of a solid object. How many surfaces does the object have? Assume hidden surfaces to be flat.

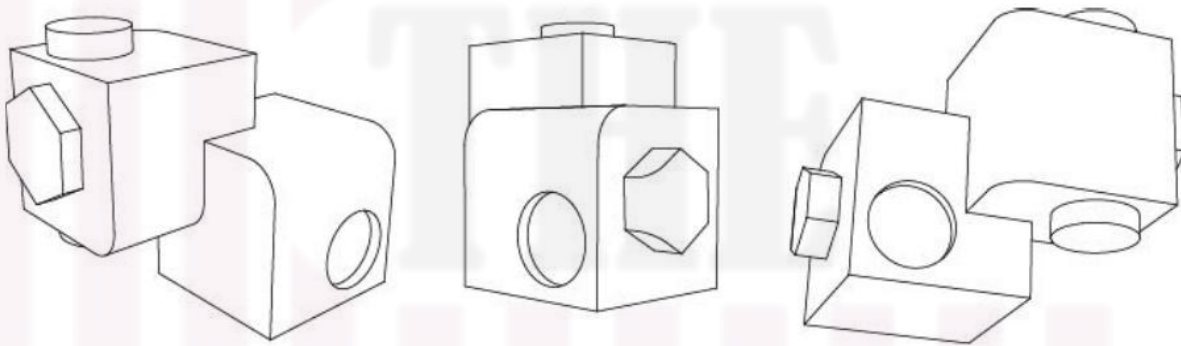

**Q.08** A monospaced font is a font in which all characters are exactly of same width. A document uses a monospaced font for typesetting where each character is exactly 0.6 cm wide. A text line in this document contains only 10 words, where each word contains 6 characters. What is the length of the line in cm?

**Part A – Section II: Multiple Select Questions**

**Q.09** Shown below are perspective views of a hexagonal prism, a cube and a cylinder, all having height 10 cm. If the objects are cut by straight planes to generate various cross sections, which of the statements is/are TRUE?

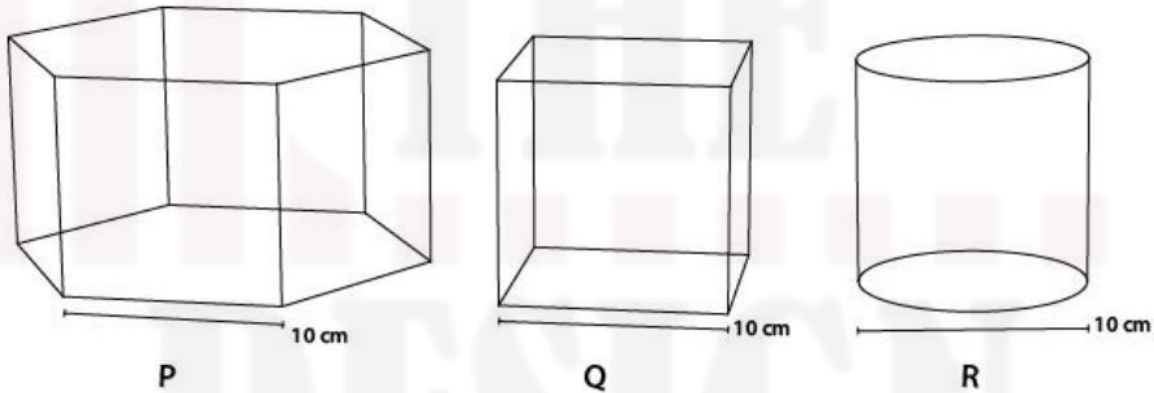

- A. R can reveal curvilinear cross section; P and R can reveal a square cross section
- B. P, Q and R can reveal rectangular cross sections; P and Q can reveal isosceles triangle
- C. P and Q can reveal regular hexagonal cross sections; R can reveal a square
- D. P and Q can reveal triangular cross sections; R can reveal a triangular cross section

**Q.10** Shown below is the front and top views of an object. Which of the options can be the CORRECT object?

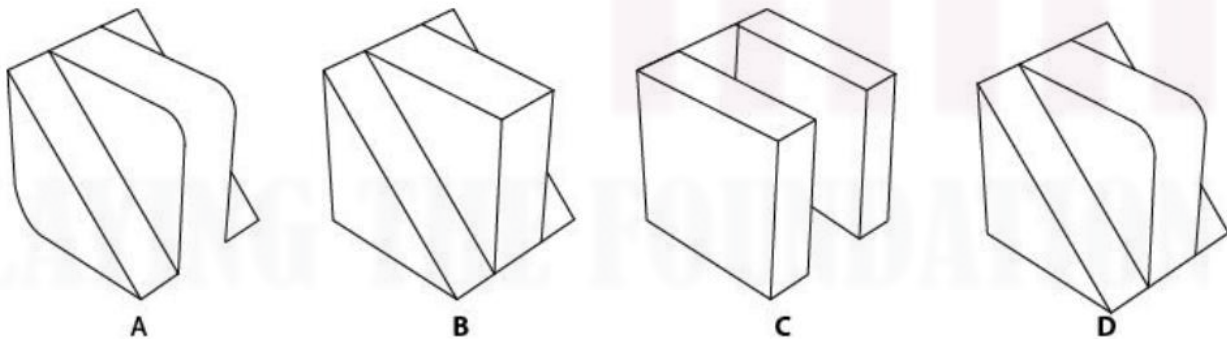

**Q.11** Shown below is a graph showing the journey of a hero in a 60-minute movie. This graph represents the relationship between time and events in the hero's journey in the film. Which of the statements is/are TRUE?

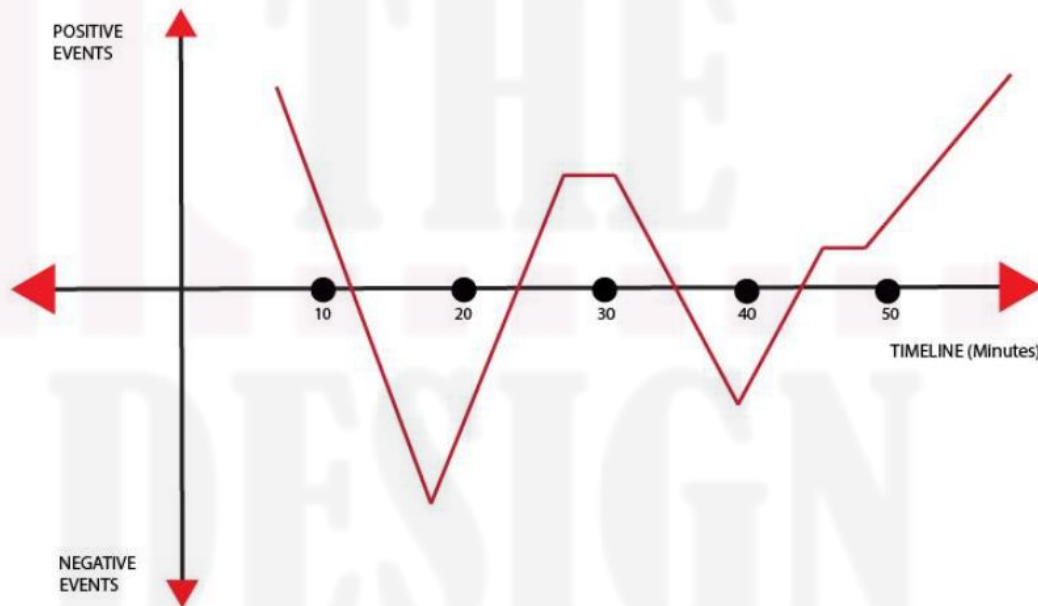

- A. The hero might have defeated the villain in the end.
- B. The hero might have encountered the death of a close friend at the 30<sup>th</sup> minute.
- C. The hero might have faced more struggles around the 40<sup>th</sup> minute as compared to the 18<sup>th</sup> minute.
- D. The hero might have met with an accident between 12<sup>th</sup> to 18<sup>th</sup> minute.

**Q.12** Shown on the left is the image of an unfolded cube. Which of the options represent(s) the folded cube?

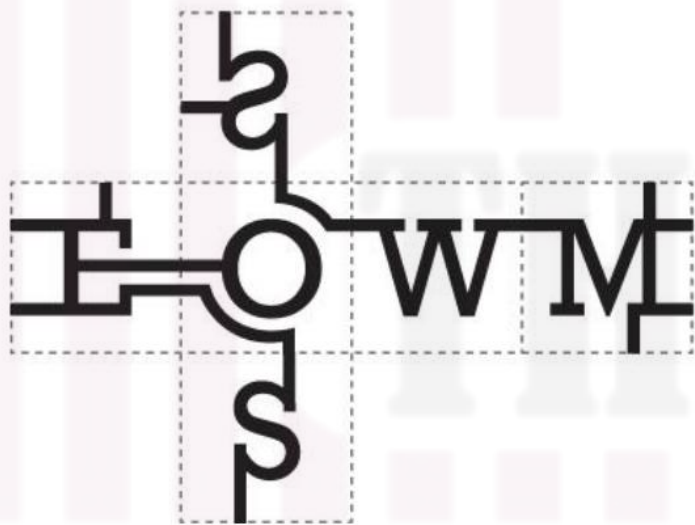

A



B



C



D

**Q.13** The figures shown below depict four mechanisms made using links and hinges, where the small circles represent hinges. Which of the options will allow relative motions between the links?

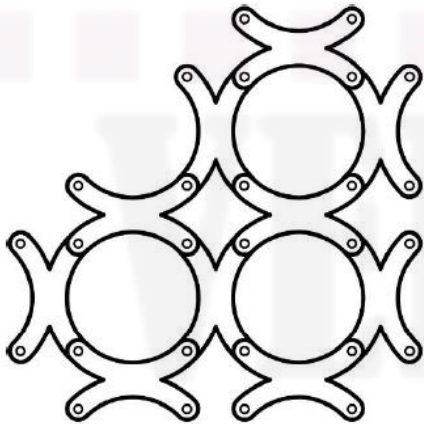

A

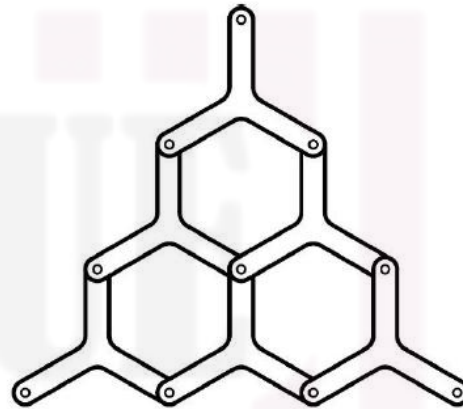

B

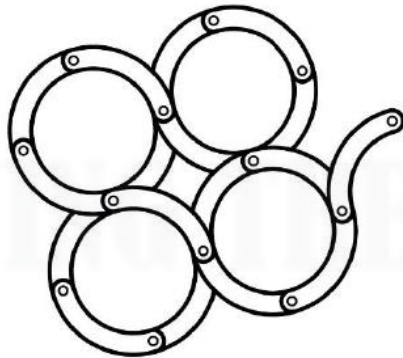

C

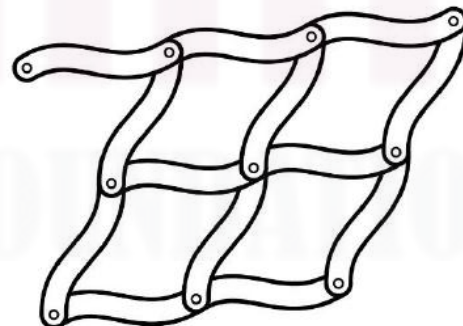

D

**Q.14** Shown below are images of chairs produced using typical manufacturing processes. Which of the following statements is/are TRUE?



P



Q



R



S

- A. P is designed for stackability; R requires many operations to manufacture.
- B. S is not designed for stackability; Q has more than five number of parts.
- C. Q is designed for stackability; S requires many operations to manufacture.
- D. R is not designed for stackability; P has less than five number of parts.

**Q.15** Shown below are four different types of scissors. Which of the following statements is/are TRUE?



P



Q



R



S

- A. P is designed for right-handed use; R is designed only for left-handed use.
- B. R is designed for right and left-handed use; Q is spring loaded.
- C. S is designed for right-handed use; P is designed for left-handed use.
- D. Q requires least effort in use; R is designed only for right-handed use.

**Q.16** Shown on the left are three tiles. Which option(s) can be made using only these tiles? Rotations of tiles are allowed.

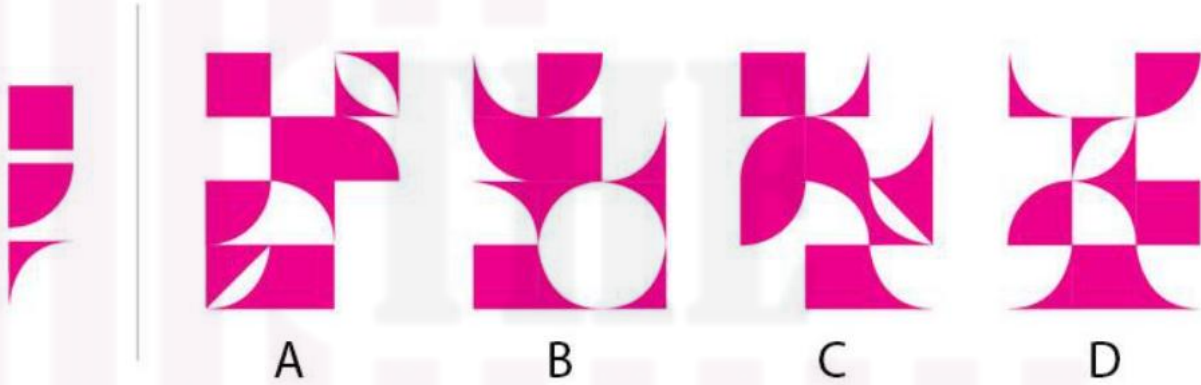

**Q.17** Shown below are images of four different models of dispensers. Which of the statements is/are TRUE?



- A. At least 2 models are based on valves; at least 2 models have hinges.
- B. 2 models are based on valves; all 4 models can be used without lifting them when 1/8 filled.
- C. At least 1 model uses lever; all 4 models can be used without lifting them when 1/8 filled.
- D. At least 1 model uses pressure for dispensing liquid; at least 1 model uses lever principle.

**Q.18** Shown below is an empty triangle which is to be filled using five tiles. Which option(s) will exactly fill this triangle when all tiles are used? Scaling, Repeating, and Flipping of tiles is

not allowed; while rotation is allowed.

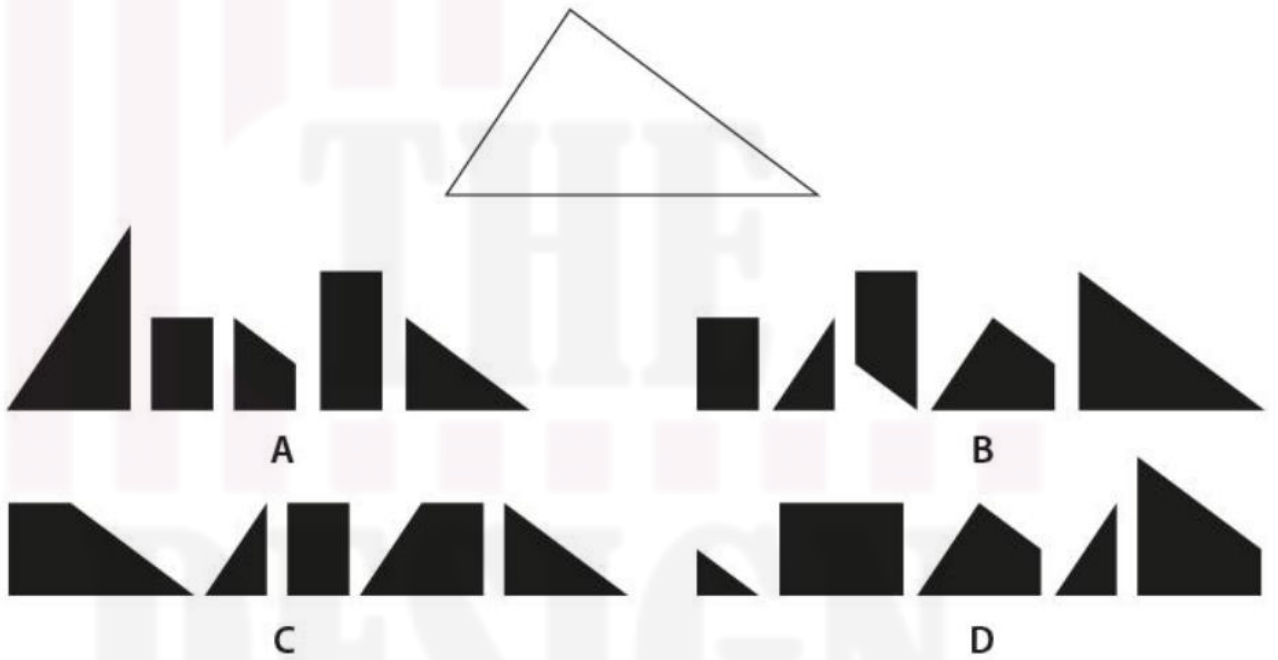

**Part A – Section III: Multiple Choice Questions**

**Q.19** Shown below are words in a particular font. Which option belongs to the same font?

Layers & Pages

O

A

O

B

O

C

O

D

**Q.20** Shown on the left is an animation loop of a mouse moving. Which option shows the CORRECT path of the mouse? [This question contains an animated GIF image.]

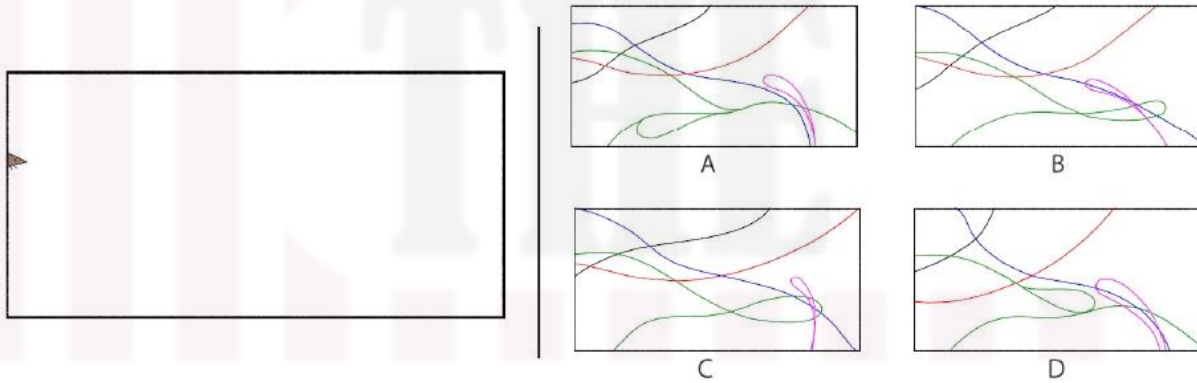

**Q.21** Which option is a simple rotation of the image given below?

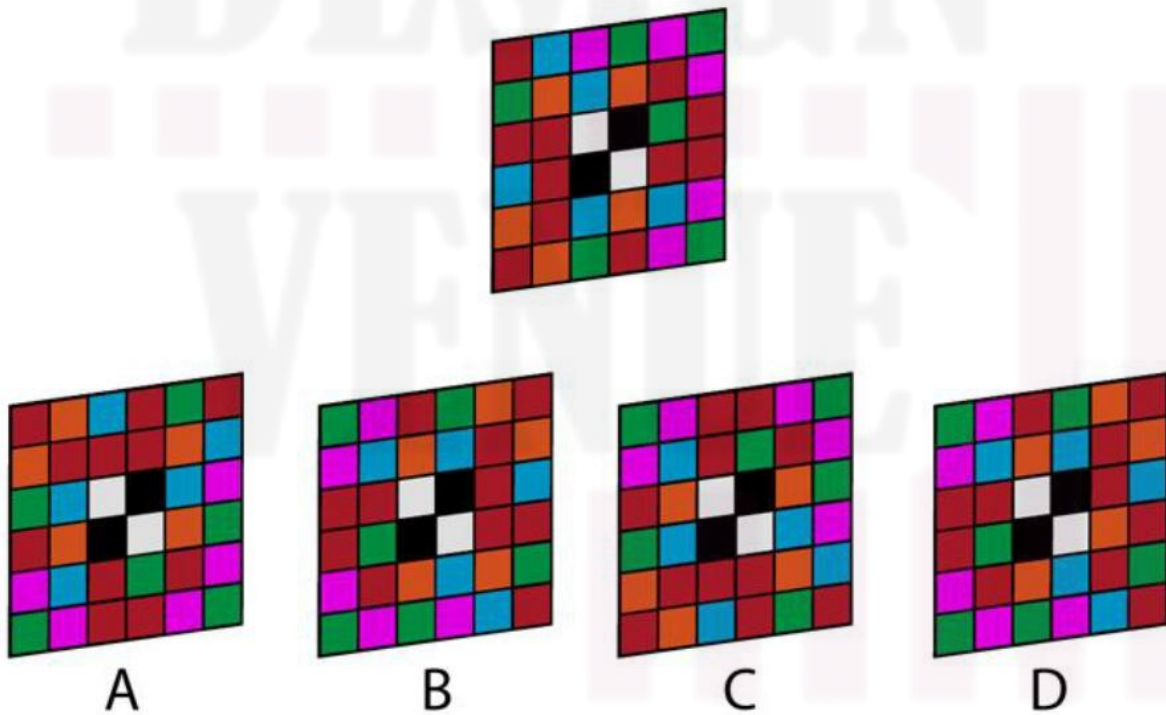

**Q 22** Which option will replace the question mark?

NOTEBOOK  
BECOMING  
?  
LEVERAGE  
RESEARCH  
AERATING

- A** MODELING
- B** RECOVERY
- C** ABSOLUTE
- D** SENTENCE

**Q.23** Shown below is a wooden artifact made using traditional materials and processes. Which option shows the relevant operations involved in its making, not necessarily in the production sequence?



- A. Chiselling, Drilling, Turning, Centering
- B. Sizing, Turning, Drilling, Lacquering
- C. Turning, Facing, Balling, Circling
- D. Turning, Lacquering, Drilling, Chiselling

**Q.24** Shown below is the perspective view of an object when viewed from the direction of the arrow. The object is first rotated by 90 degrees clockwise about the y-axis, then 180 degrees anti-clockwise about the x-axis, followed by 90 degrees anti-clockwise about the y-axis. All rotations are as viewed from a point on the positive axis towards the origin of the respective axes. Which option shows the CORRECT resultant view?

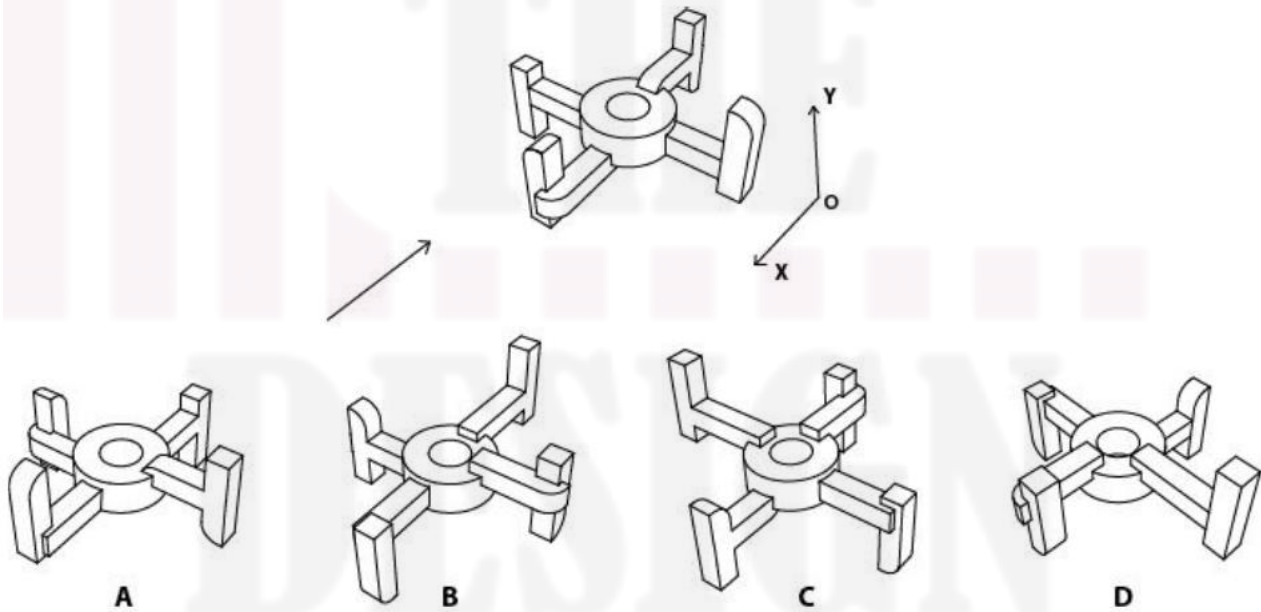

**Q.25** Shown below is an image that shows the step-by-step process of folding a white colour fabric. The folded fabric is dipped into colour at three corners P, Q and R as indicated in the image. What will be the resultant fabric after unfolding?

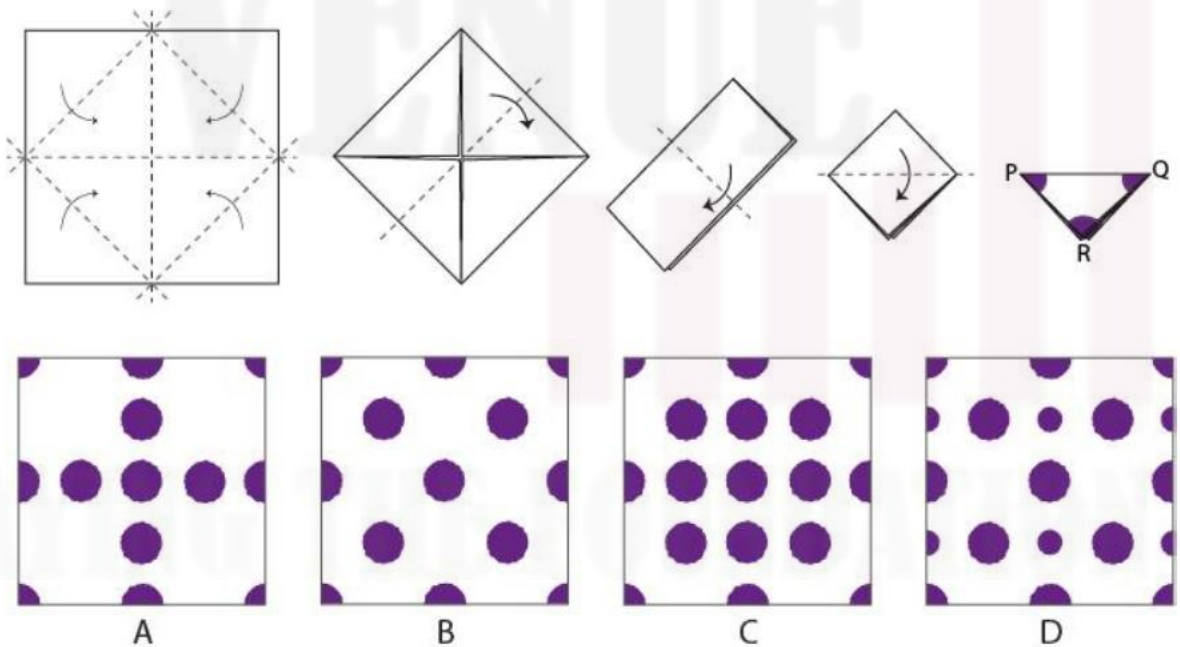

**Q.26** Which arrangement of tiles will create the image shown on the left? Tiles can be rotated but not flipped.

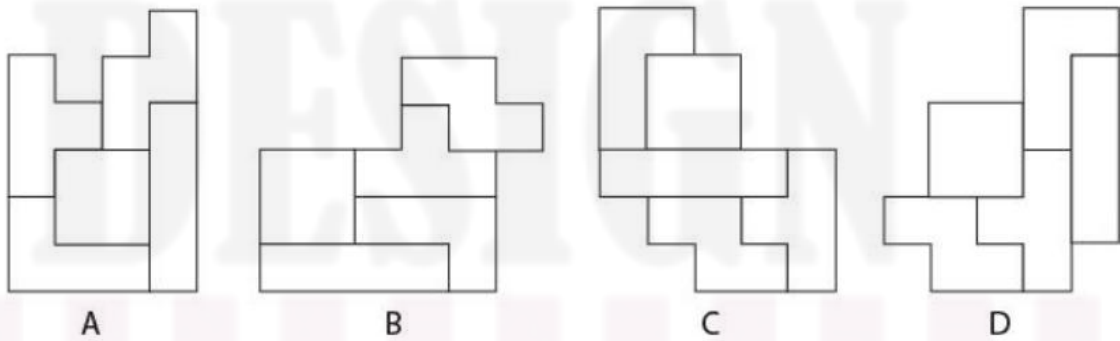
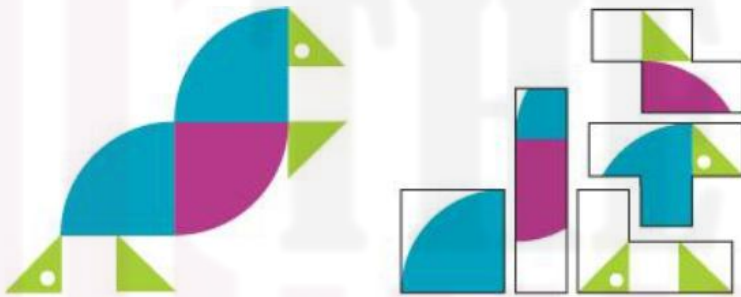

**Q.27** Which option will replace the question mark?

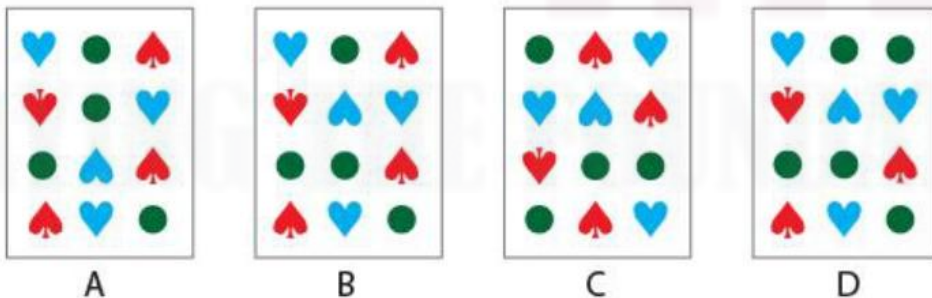
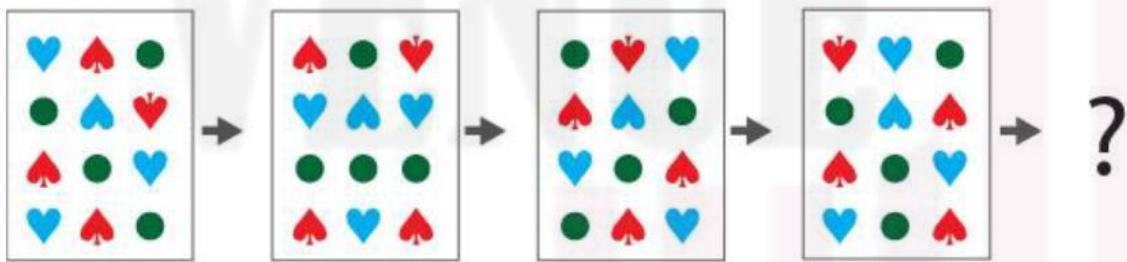

**Q.28** Which option will replace the question mark?

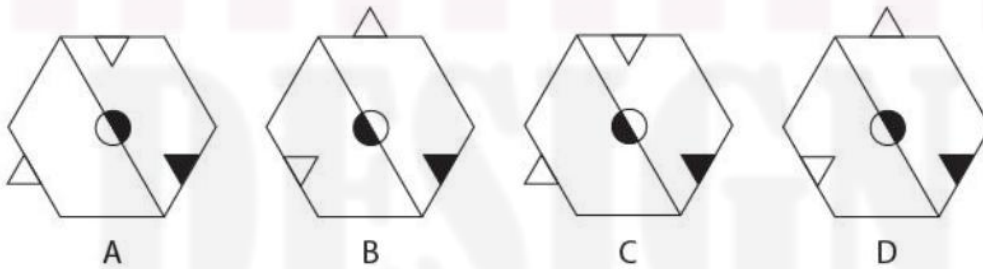
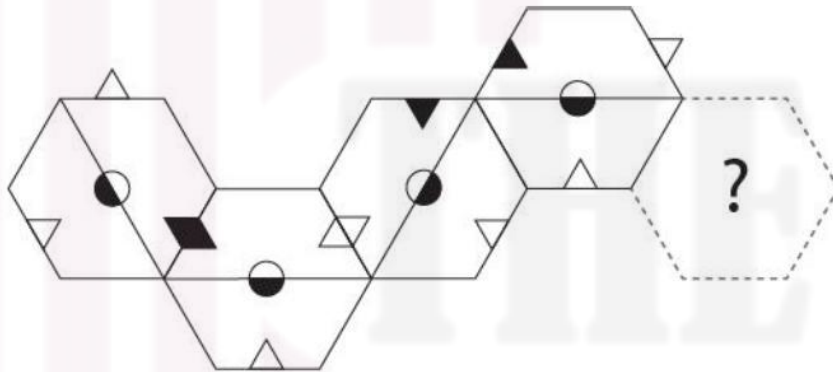

**Q.29** A circular disc and a sphere of the same diameter are floating above the ground. The circular disc is parallel to the ground. Which option shows the CORRECT set of shadows on the ground when seen from the top?

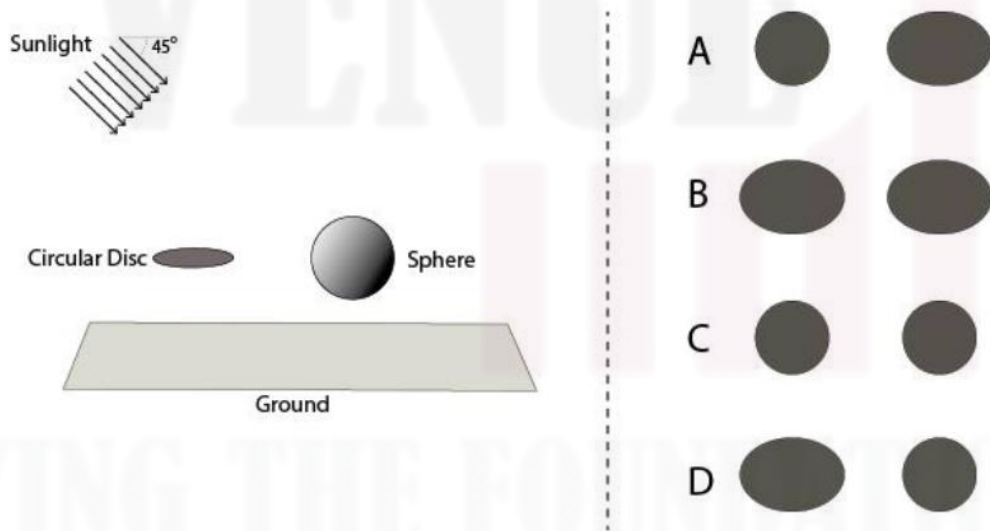

**Q.30** Shown on the left is an image. Which option is the correct profile of the image?

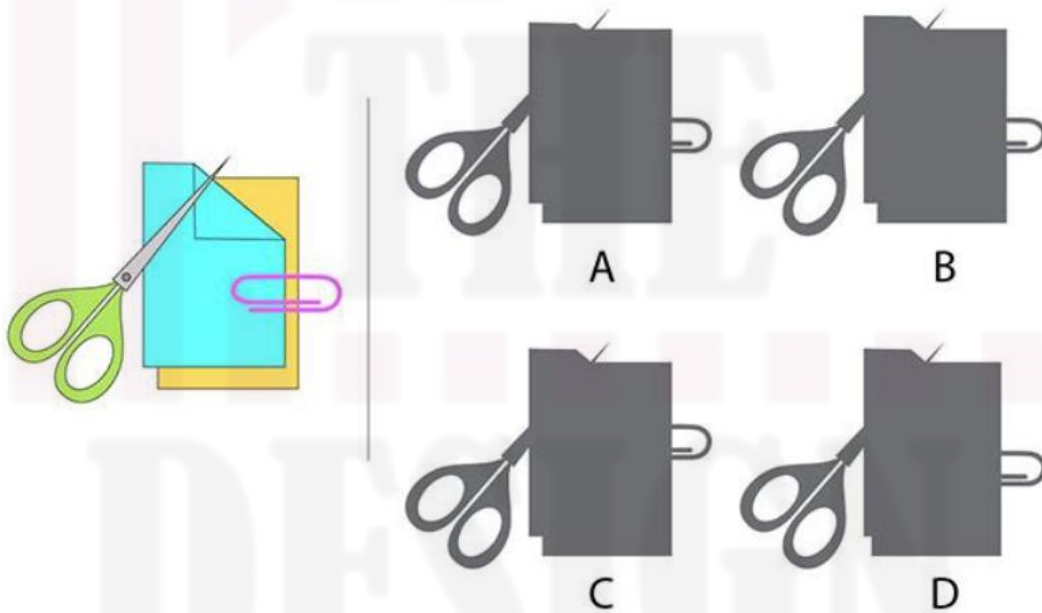

**Q.31** Which option is the mirror image of the sentence shown on the left?

The moon shines high when  
the night sleeps deep.

The moon shines high when  
the night sleeps deep.

A

The moon shines high when  
the night sleeps deep.

B

The moon shines high when  
the night sleeps deep.

C

The moon shines high when  
the night sleeps deep.

D

**Q.32** Shown below is an artistic representation of various dance forms of India. Which option shows the correct sequence of the dance forms?



- A. Kathakali, Bharatanatyam, Chhau, Mohiniyattam
- B. Manipuri, Chhau, Kathak, Kathakali
- C. Mohiniyattam, Chhau, Bharatanatyam, Kathakali
- D. Manipuri, Chhau, Bharatanatyam, Kathakali

**Q.33** Shown on the left is an image printed on a transparent sheet. If this sheet is folded along the dotted line, then which option will be the resultant view?

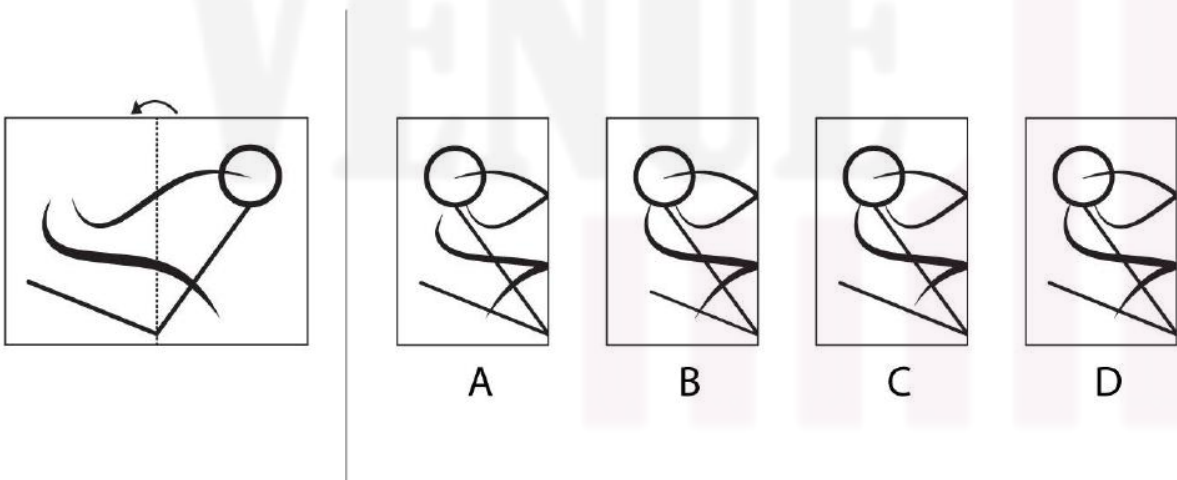

**Q.34** Shown below are the key frames of a character lifting a sack. Which option will replace the question mark?

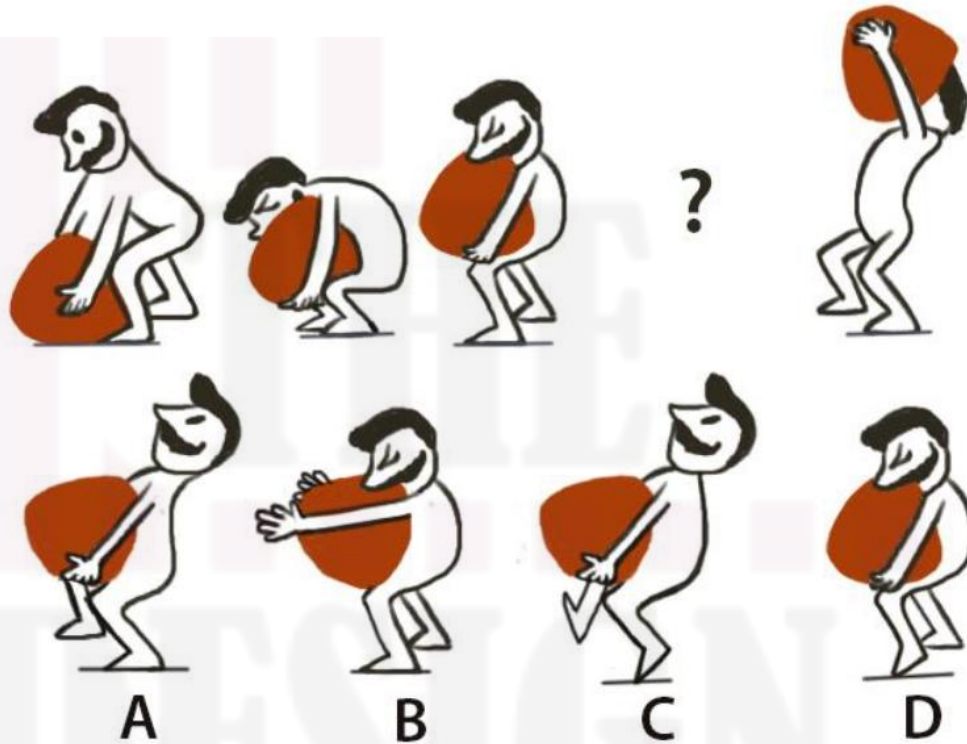

**Q.35** Shown below is an animation of a bird flying. Which frame is NOT present in the animation?

[This question contains an [animated GIF image.](#)]

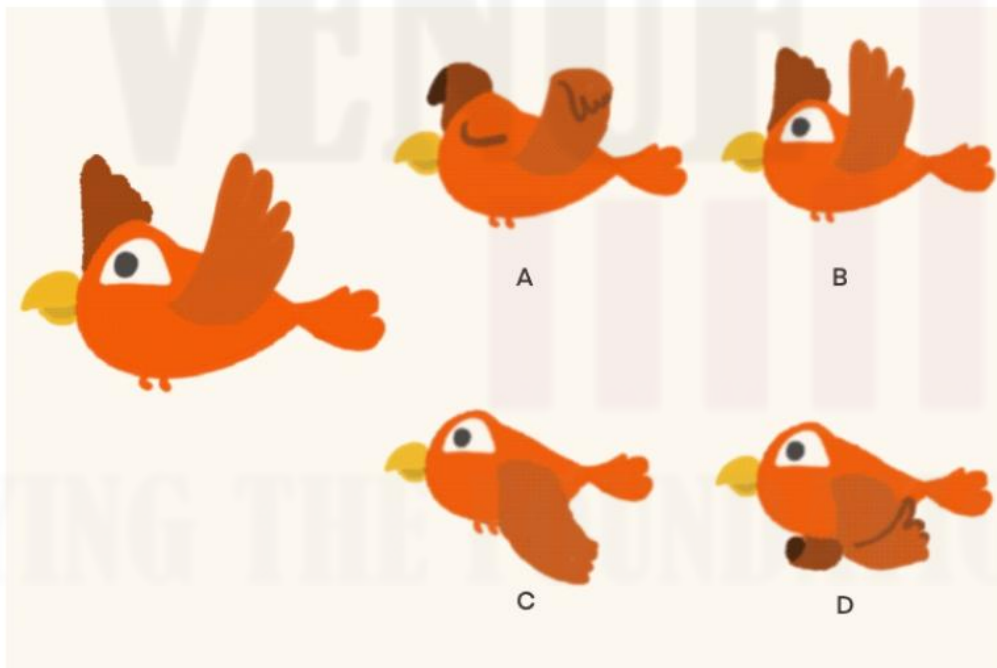

**Q. 36** A colour image is shown on the left. If the blue sky is painted black and the leaves are painted white, which is the CORRECT black and white image among the scaled options shown on the right?

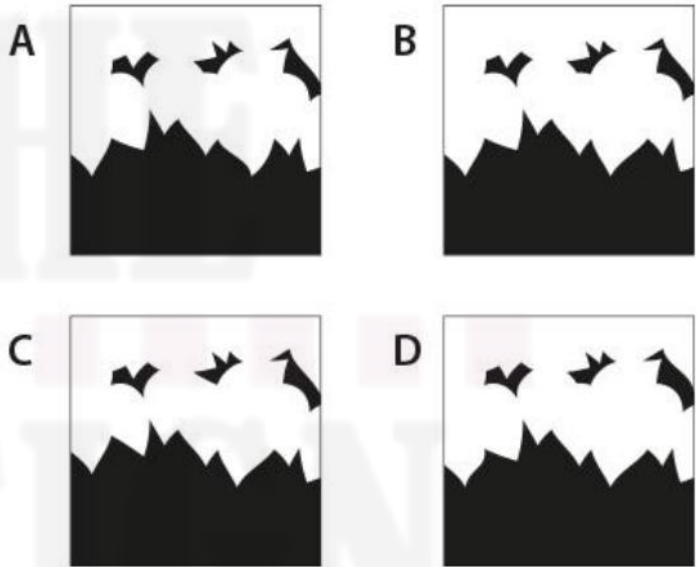

**Q.37** Shown below are frames from a film sequence that follow the 180-degree rule in cinematography. Which option will replace the question mark?



A

B

C

D

**Q.38** Shown below on the left are two views of a bent wire. Which option is the top view of the wire?

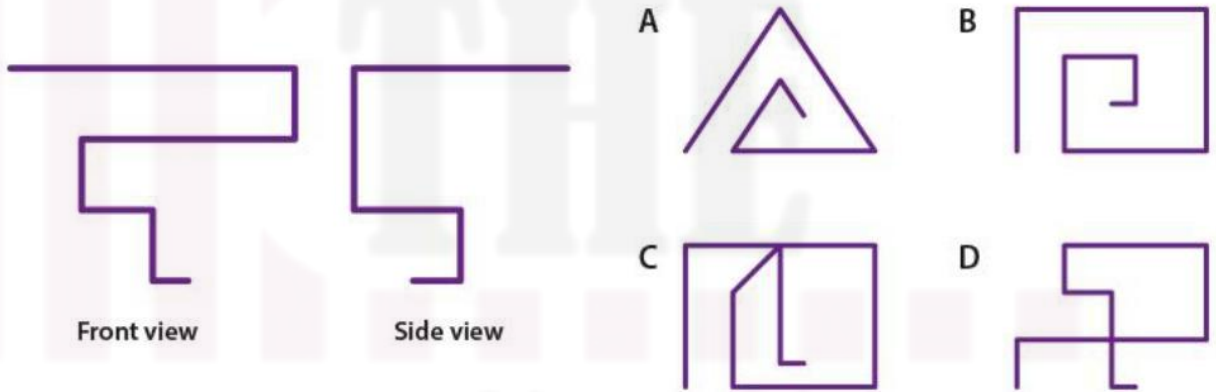

**Q.39** Shown on the left is a set of equations. Which option belongs to the same set?

$\triangle \times \triangle = \square$	<b>A</b> $\triangle \times \otimes = 12$
$\square + \triangle = \boxtimes$	<b>B</b> $\boxtimes + \triangle = 20$
$\triangle \times \otimes = \boxtimes$	<b>C</b> $\otimes \times \otimes = 25$
$\boxtimes + \otimes = 25$	<b>D</b> $\square + \otimes = 28$

**Q.40** A sheet of paper is folded along the white dotted lines and then cut along black dotted lines as depicted below. Out of the four scaled down options, which is the CORRECT resultant unfolded paper?

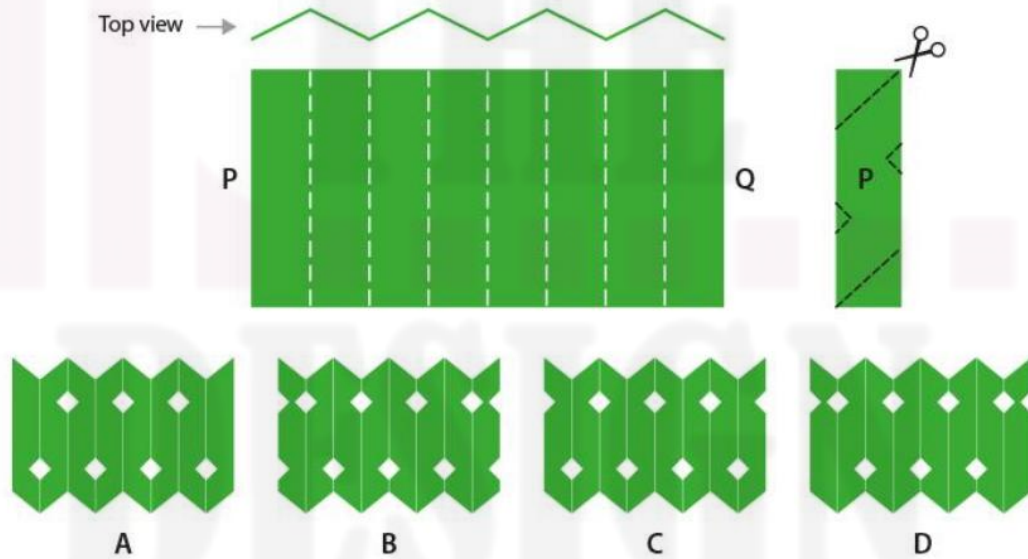

**Q.41** A square pyramid sequentially passes through three cut-outs, namely, 1, 2 and 3, without changing its orientation. Each cut-out has a circle with notches as shown. The cut-outs scrape off parts of the pyramid as it passes through them. Which option shows the CORRECT Side View of the remaining part of the pyramid at the end of the sequence?

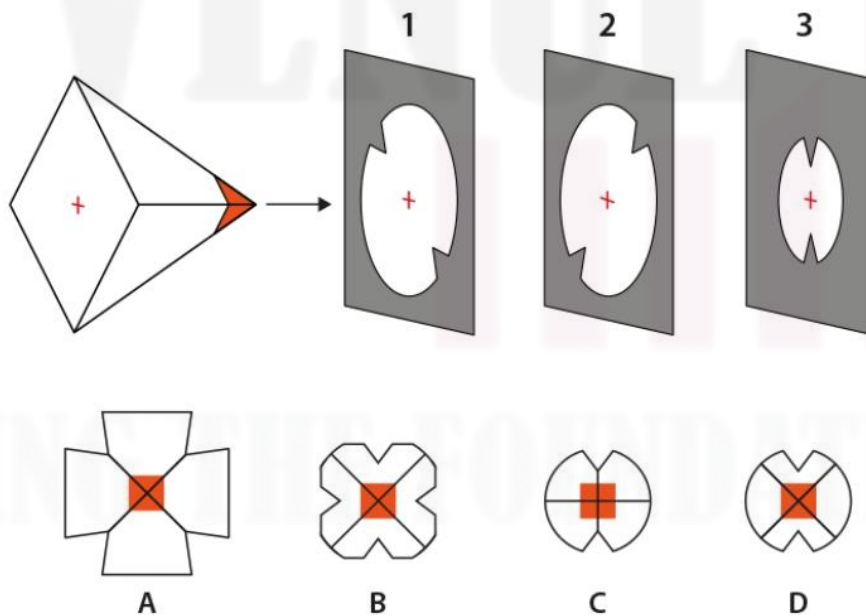

**Q.42** Shown below is a configuration of a circle and a rigid rod. The length of the rod PQ is equal to the circumference of the green circle. The rod tangentially revolves around the circle till point Q reaches point P. Which option represents the CORRECT tracing of point Q?



**Q.43** When "See you Bye" is spoken, which option shows the correct sequence of lip movement?

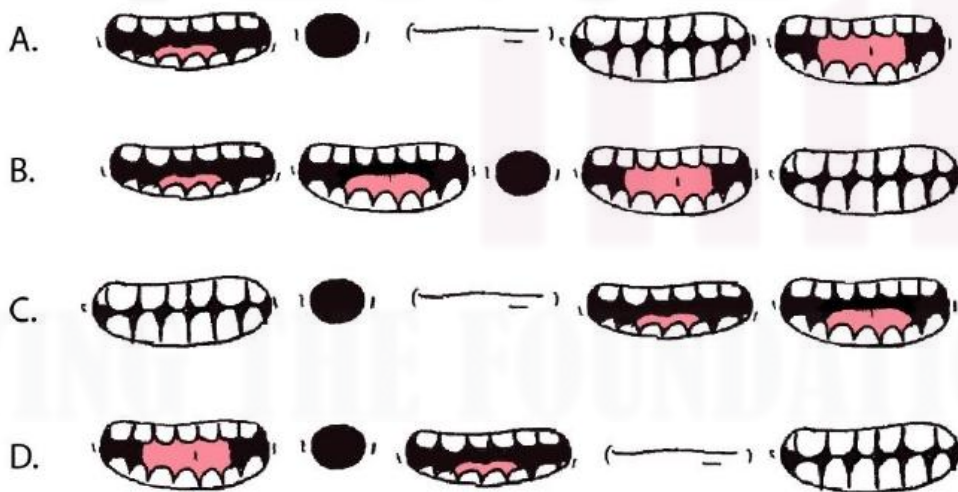

**Q.44** Which option has all four parts, that belong to the disc shown on the left?

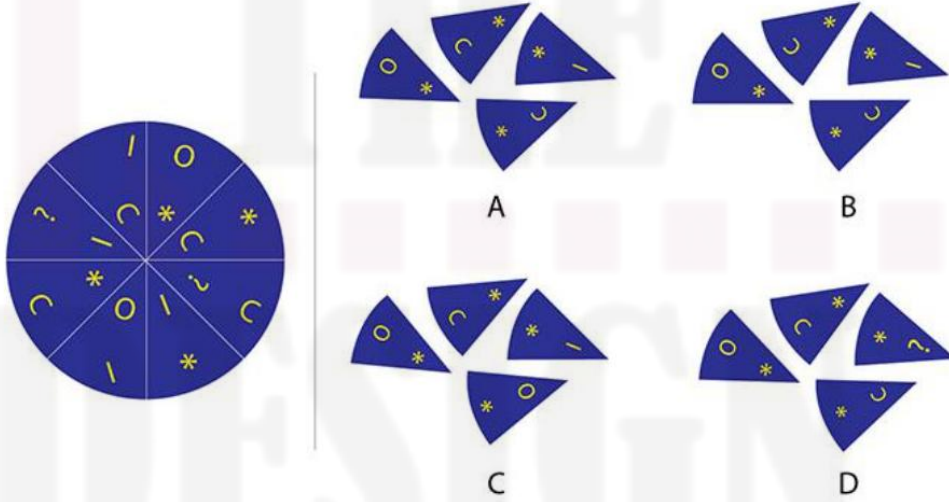

## Part B

### **All questions are mandatory**

**Q.1 SKETCHING:** Mandatory question (20 marks = 4 x 5 marks)

Two kids, Kaa and Kii, are on an adventure trip in a forest. While exploring, suddenly a bear emerges and starts chasing them. The kids start running in panic through the forest. A fox is watching the whole scene. Sketch this scene from the fox's point of view. The sketch should be clear and visible.

Additional Instructions:

- Use only black/HB-series pencils
- Do not use other colours
- Draw only in the given space

Evaluation Criteria:

- Character and expressions
- Proportion and composition
- Quality of sketching
- Environment and props

**Q.2 CREATIVITY:** Mandatory question (20 marks = 4 x 5 marks)

Shown below is a canvas with four frames containing certain elements. Create a meaningful sequence of visuals using the elements in the frames. Ensure that continuity is maintained across the frames by using additional prop(s) and/or character(s) as needed. You may choose to create the sequence either from left to right or right to left, but indicate the direction using an arrow. Give an appropriate title in the space provided.

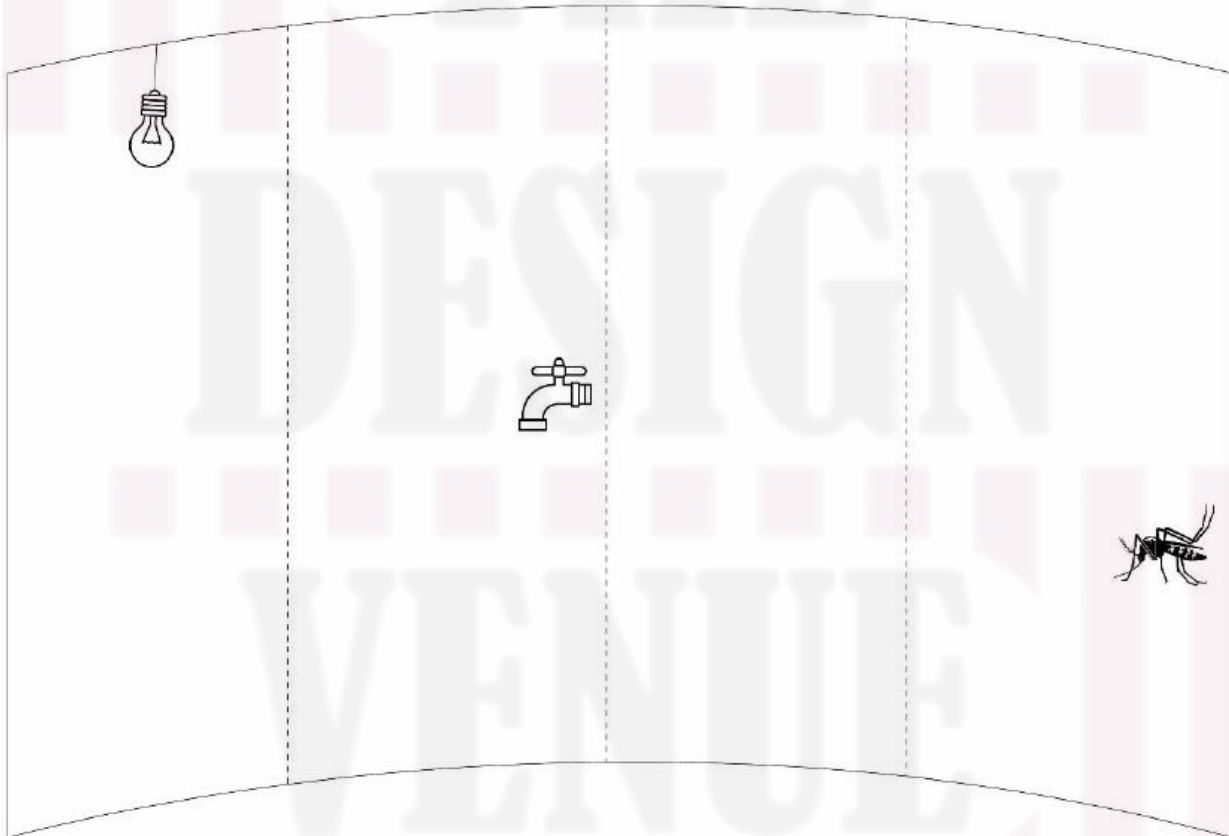

Evaluation criteria:

1. Imagination and Creative ideas
2. Composition
3. Drawing quality and clarity
4. Continuity in the sequence

**Q.3 VISUAL SENSITIVITY: Mandatory question (20 marks = 4 x 5 marks)**

Shown below are new animals that have been acquired by an Indian Zoo.

- A. Indian Grey Mongoose
- B. Honey Badger
- C. Indian Bison
- D. Indian Pangolin

The Zoo wishes to create a signage to guide visitors around the enclosures of these animals. Create four icons using only BLACK colour to indicate the animal in the enclosure. All icons should be clear and visible, and have a consistent visual language. Draw the icons in the FOUR squares provided in the answer booklet.



A



B



C



D

**Evaluation criteria:**

1. Consistency in the visual language
2. Representation of the animals
3. Visual composition
4. Clarity and neatness

**Q.4 FORM SENSITIVITY:** Mandatory question (20 marks = 4 x 5 marks)

Shown on the left is a character-based design of a product. Inspired from this product, re-imagine, conceptualise, and render the tea flask given on the right. Make it clear and visible.



**Evaluation Criteria:**

- Characterization of the product
- Relevant details and usability
- Quality of sketching
- Surface shading/rendering

**Q.5 PROBLEM IDENTIFICATION: Mandatory question (20 marks = [5+5] + [5+5] marks)**

A typical vegetable cart, as seen in India, is shown below.



- A. Identify and list FIVE distinct problems from a buyer's point of view and FIVE distinct problems from a seller's point of view in this context. List the problems only in the given space. (5 + 5 marks)
- B. From the above-listed problems, draw and visually explain any ONE problem of the buyers, and any ONE problem of the sellers in the given boxes. (5 + 5 marks)

Additional Instructions:

1. Do not limit yourself to the buyer and seller in the given image.
2. Write the identified problems only on the dotted lines.
3. Draw and visually explain the listed problems only in the given boxes.

Evaluation Criteria:

1. Ability to identify unique and relevant problems in the given context
2. Severity of the problems identified
3. Ability to communicate problems through visuals
4. Presentation, clarity and neatness

# The Design Venue:

## Your Gateway to Design Excellence!



**THE  
DESIGN  
VENUE**

# PIONEERS IN NID, NIFT, U/CEED & NATA COACHING

Turn your design dreams into reality with expert guidance from industry leaders.

**Contact Now**



+91 9886452274



THEDESIGNVENUE.COM

**Join TODAY**