



LAYING THE FOUNDATION

## CEED 2017

STUDENTS NAME:-----

CONTACT NUMBER:-----

WHATSAPP NUMBER:-----

EMAIL ID:-----

**Get a detailed analysis of your answers from the experts in 3 simple steps**

*1. Answer the question paper*

*2. Click the picture on your mobile*

*3. WhatsApp it to 9886452274, 988603418 or meet us in person and get it analyzed face to face*

For more question papers and to get tips and tricks to crack architecture and design entrance exams visit us on [www.thedesignvenue.com](http://www.thedesignvenue.com) or call us on +91 9886452274, +91 9886034182

## CEED 2017 Question Paper

### Instructions

1. The total duration of the examination is 3 hours. The question paper contains two parts - Part A and Part B. The duration of Part A is one hour. The duration of Part B is two hours. Part B will start only after Part A ends. Part A cannot be attempted after Part B commences.
2. Questions of Part A and Part B will appear on the computer. Answers to Part A have to be entered in the computer. Answers to Part B have to be given in the answer book provided by the invigilator.
3. Part A carries a total of 100 marks. It contains 3 sections: Section I, Section II and Section III.
4. Part A, Section I (total 30 marks) contains a total of 10 **Numerical Answer Type (NAT)** questions. For these questions, the answer is a number that needs to be entered using the virtual keyboard on the monitor. No choices will be shown for these questions. Each correct answer will be awarded 3 marks. Questions not attempted will be awarded zero marks. There is no negative or partial marking for this section.
5. Part A, Section II (total 20 marks) contains a total of 10 **Multiple Select Questions (MSQs)**. Each MSQ has four choices of which one or more is/are the correct answer(s). The candidate gets 2 marks only if she / he selects all the correct answers for a given MSQ. Questions not attempted will be awarded zero marks. There is no negative or partial marking for this section.
6. Part A, Section III (total 50 marks) contains 25 **Multiple Choice Questions (MCQs)**. Each MCQ has four choices of which only one is the correct answer. In this section, each correct answer will be awarded 2 marks and each wrong answer will be awarded -0.6 marks. Questions not attempted will be awarded zero marks.
7. Blank paper sheets will be provided for rough work for Part A. These have to be returned to the invigilator at the end of the exam.
8. Part B carries a total of 100 marks. It contains 8 questions. You may choose to answer any ONE of Questions 1, 2, 3, 4 and 5. Questions 6, 7 and 8 are mandatory. Each question must be answered on the page(s) designated for that question in the answer book. Additional instructions to Part B questions are provided in the answer book.
9. Charts, graph sheets, tables, calculators, cellular phones and other electronic gadgets are not allowed in the examination hall.
10. In Part B, colour pencils, crayons, sketch pens etc. may be used unless otherwise specified in the questions.

## Part A – Section I: NAT

Q.01 How many unique shapes are shown in the image below?



Q.02 If B is an extruded form of A, how many surfaces will the extruded form of C have?



A

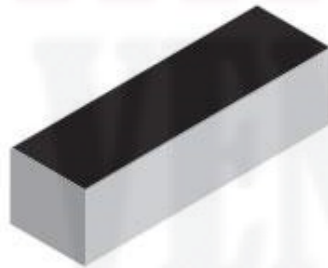

B



C

Q.03 Four boxes are shown below. The numbers within each box have a specific relationship. What number would replace the question mark?

3	6
6	6

1	6
2	8

4	2
7	6

3	?
9	4

Q.04 A square with a side of 5 cm was cut along the dotted lines as shown in the figure. This created a square piece of side 3 cm. The centres of the two squares are the same. What is the area (in  $\text{cm}^2$ ) of the shaded portion?

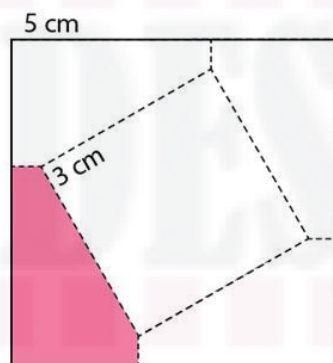

Q.05 A forest lies between two parts of a city. How many unique routes are there to go from the west side to point A in the east side without retracing any portion of the route?



Q.06 How many pentagons are there in the 3-dimensional structure shown below?



Q.07 Some cubes are missing from a  $4 \times 8 \times 8$  tightly packed structure made of alternating white and blue solid cubes as shown below. No cubes have been removed from the portion that is not visible. What is the total number of blue cubes in this structure?

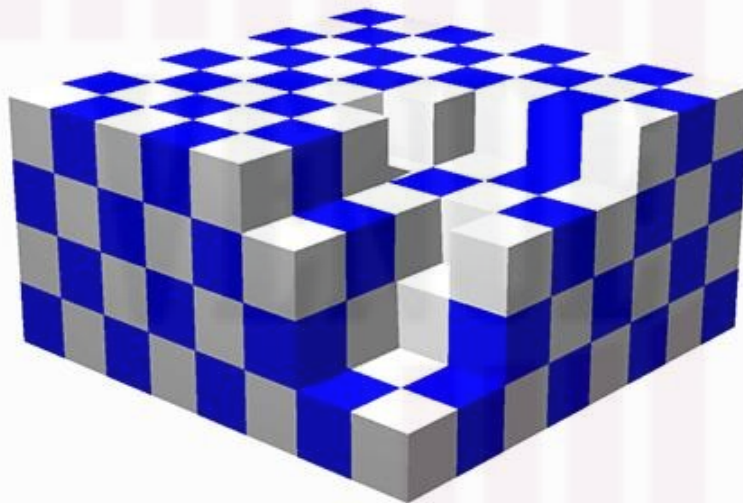

Q.08 Shown below are two perspective views of a solid object. The pipe section has three identical cuts on its surface along with three identical flanges. How many surfaces are there?

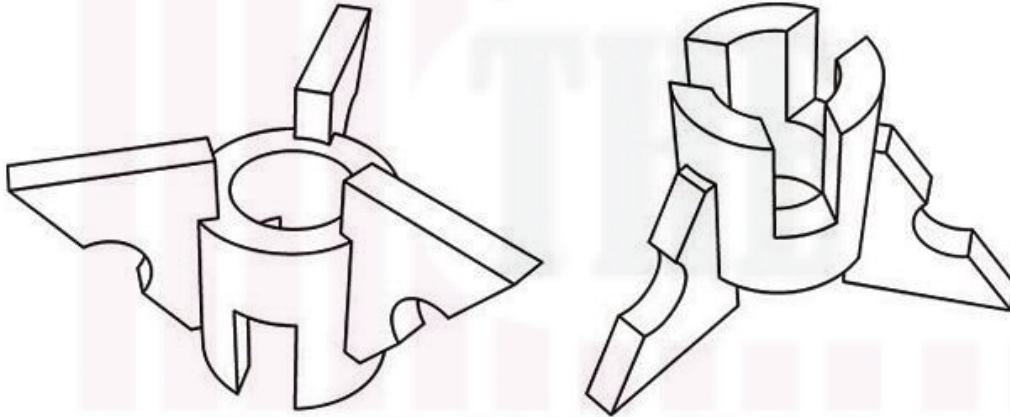

Q.09 A UNION of three solids (a cylinder of diameter 20 units, a cuboid of side 20 units, and a triangular prism with base of the triangle 20 units and height 20 units) is shown below. Visualise the new solid formed by the INTERSECTION of these three solids in this arrangement. How many surfaces will the resultant solid have?

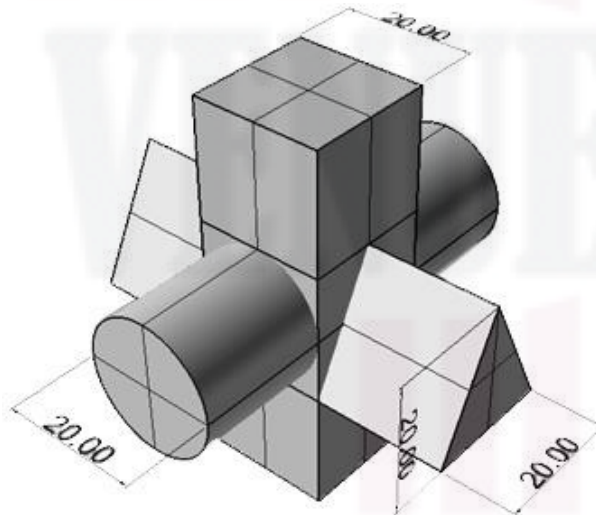

Q.10 Shown in the figure are circles of diameter 42 cm. What is the total length (in cm) of the path LRMNOP as indicated by the red arrows? Assume  $\pi = 22/7$ .

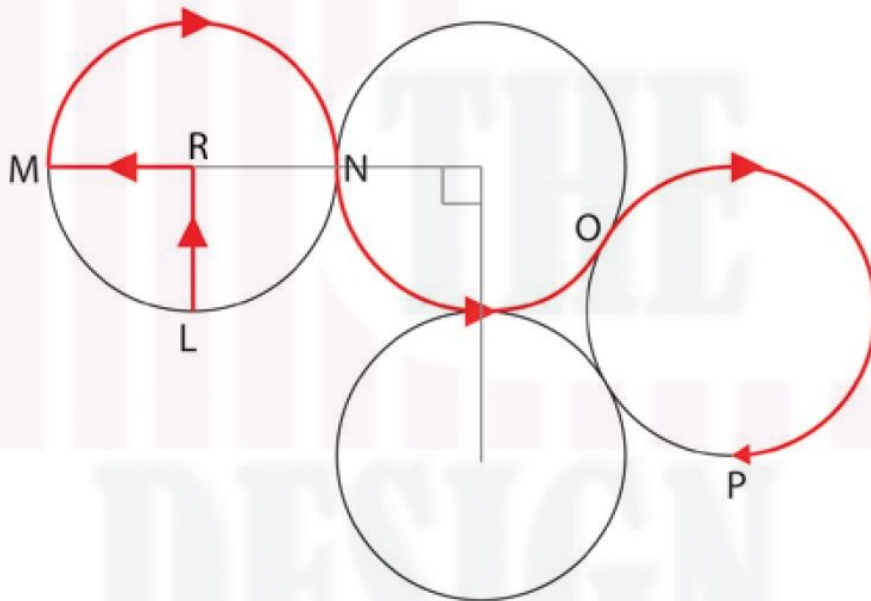

## Part A – Section II: MSQ

11. Five statements are given below:

- Bulls move faster than Snails
- Cats move slower than Bulls
- Snails move faster than Dogs
- Dogs move slower than Bulls
- Cats move faster than Snails

If all of the above statements are TRUE, which of the following statement(s) is/are FALSE:

- A. Cats move faster than Bulls
- B. Dogs move slower than Cats
- C. Bulls move faster than Dogs
- D. Bulls move slower than Cats

Q.12 In the frame below, parts of logos of a type of Indian organisations are shown. Which of the option(s) is/are part of logos of same type of organisations?



A



B



C



D

Q.13 Which of the following term(s) is/are associated with human colour perception?

- A. Blind spot
- B. Colour blindness
- C. After image
- D. Inter-ocular distance



Q.14 Which of the following cross-section(s) could be produced by cutting a cube with a plane?

- A. Square
- B. Triangle
- C. Pentagon
- D. Hexagon

Q.15 The front and top views of an object are identical, as shown in figure A. Which of the option(s) can be left side view of the object?

Figure A

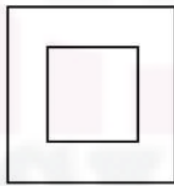

A

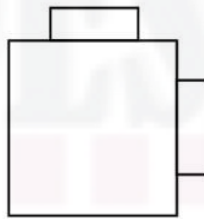

B



C

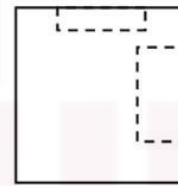

D

Q.16 Which of the following form(s) can be placed on a flat floor in such a way that there are no overhanging elements, i.e. cantilevers?



A

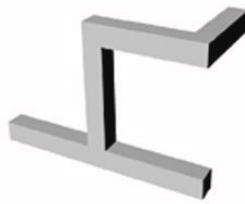

B



C



D

Q.17 The figures show four different schematics of a flexible thread. If the ends are pulled apart, which of the schematic(s) will form a knot?

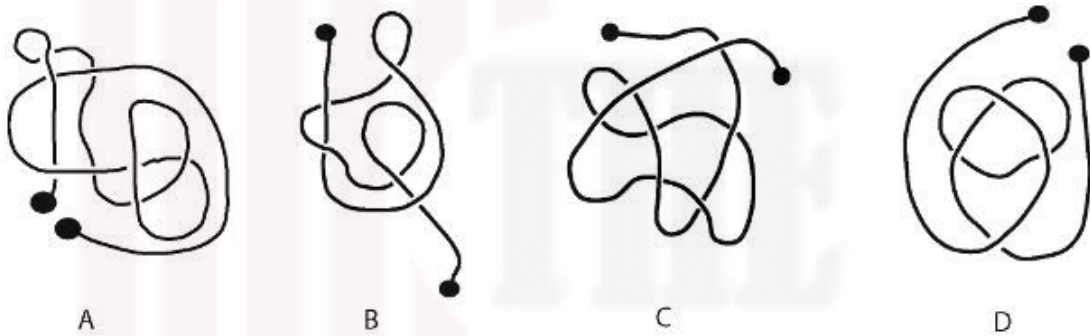

Q.18 Image below shows the parts of a *tangram*. Size of one of the parts has been changed in one or more of the option(s). Identify those option(s).

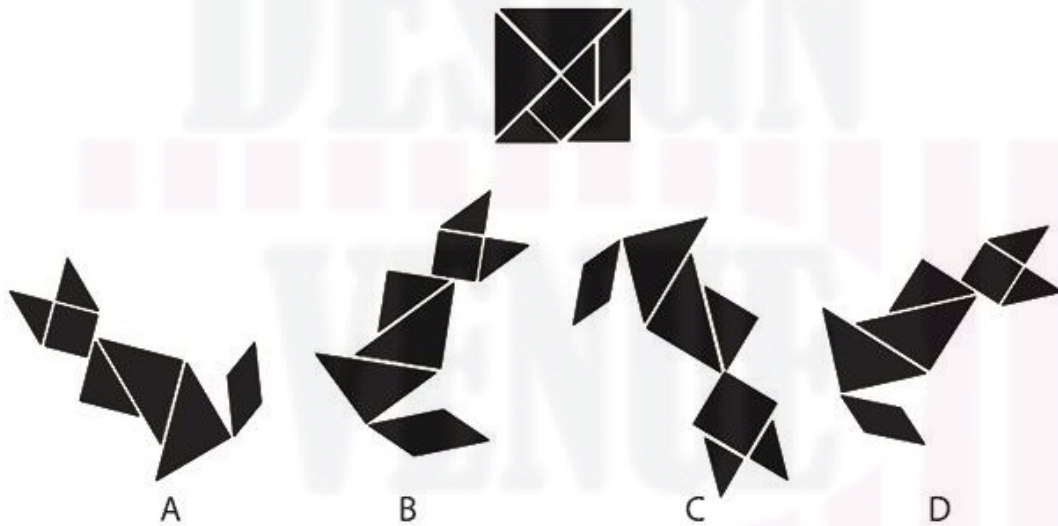

Q.19 Which of the painting(s) is/are by Picasso?



A



B

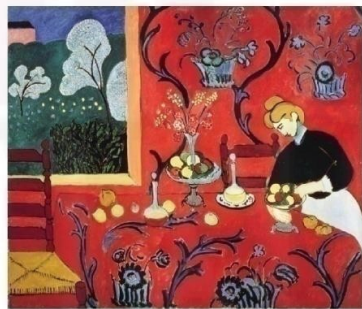

C

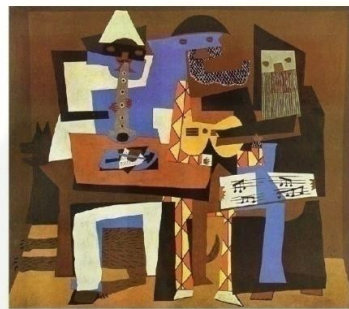

D

Q.20 Which of the following film(s) is/are directed by Shyam Benegal?

- A. Manthan
- B. Bhumika
- C. Droh Kaal
- D. Nishant

## Part A – Section III: MCQ

Q.21 The word shown below uses a specific font. From the options, choose the letter which belongs to the same font.

colder

a

A

a

B

a

C

a

D

22. Given below is an excerpt from a speech given by a famous person in 1940.

“Of course, relative non-violence on the whole is doubtless a virtue so pre-eminently contributing to human good as to form one of the fundamentals on which human life whether individual or social can take its stand and evolve all social amenities. But absolute non-violence, that is non-violence under all circumstances and even when instead of helping human life whether individual or national, it causes an incalculable harm to humanity as a whole, ought to be condemned as a moral perversity and is on the whole condemned likewise by those very religious and moral schools which lauded relative non-violence as the first and foremost human virtue. The ahimsa of the Jains and Buddhists is opposed to this Gandhist Doctrine of ahimsa.”

Identify the person.

- A. B. R. Ambedkar
- B. V. D. Savarkar
- C. Lokmanya Tilak
- D. Jawaharlal Nehru

Q.23 Identify the figure which replaces the question marks.

?	?	▼	▲	◆	△
?	?	■	▽	■	▽
△	▼	▲	◆	△	▼
▽	■	▽	■	▽	■
▼	▲	◆	△	▼	▲
■	▽	■	▽	■	▽

◆	▲
■	▽

A

◆	△
■	▽

B

▼	▲
■	▽

C

▲	◆
▽	■

D

Q.24 An ant walks along a helical path on a solid cylindrical object of diameter 5 cm and height 5 cm. It starts walking from point X, goes around the object, and reaches point Y, which is vertically below point X as shown in the figure. How much distance did the ant walk?

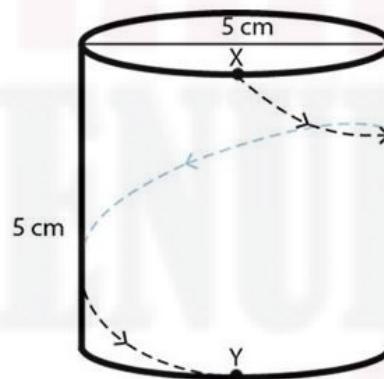

- A.  $\sqrt{25 + 25\pi^2}$  cm
- B.  $\sqrt{25 + 100\pi^2}$  cm
- C.  $25 + 25\pi^2$  cm
- D.  $5 + 5\pi$  cm

Q.25 In a secret language, if CAT becomes BES, DOG becomes CUF, then KIN should become?

- A. LOP
- B. LEP
- C. JEM
- D. JOM

Q.26 Match the States and National Parks in the columns below.

- |                |                |
|----------------|----------------|
| 1. Rajasthan   | p. Jim Corbett |
| 2. Kerala      | q. Bandipur    |
| 3. Uttarakhand | r. Manas       |
| 4. Assam       | s. Ranthambore |
| 5. Karnataka   | t. Periyar     |

- A. 1-q, 2-p, 3-t, 4-s, 5-r  
B. 1-s, 2-t, 3-p, 4-r, 5-q  
C. 1-t, 2-p, 3-r, 4-q, 5-s  
D. 1-s, 2-p, 3-t, 4-q, 5-r

Q.27 Identify the manufacturer of the motorcycle from the picture shown below.



- A. Bajaj  
B. Hero Honda  
C. Royal Enfield  
D. TVS

Q.28 The picture on the left is the image of a dial on a digital camera. The symbol on the right enlarged from the dial represents a mode. Which mode does it represent?

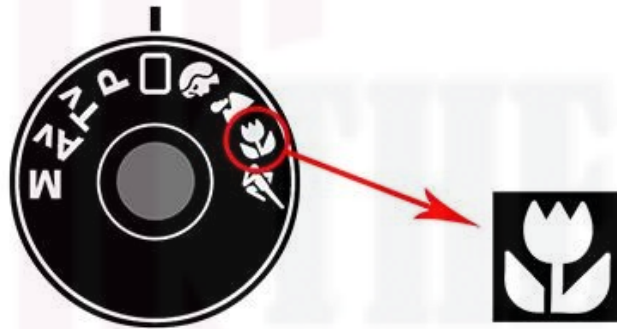

- A. Close-up mode
- B. Daylight mode
- C. Vivid mode
- D. Still life mode

Q.29 View X and View Y show the same object from different angles. Identify the missing sign on the object in View Z.

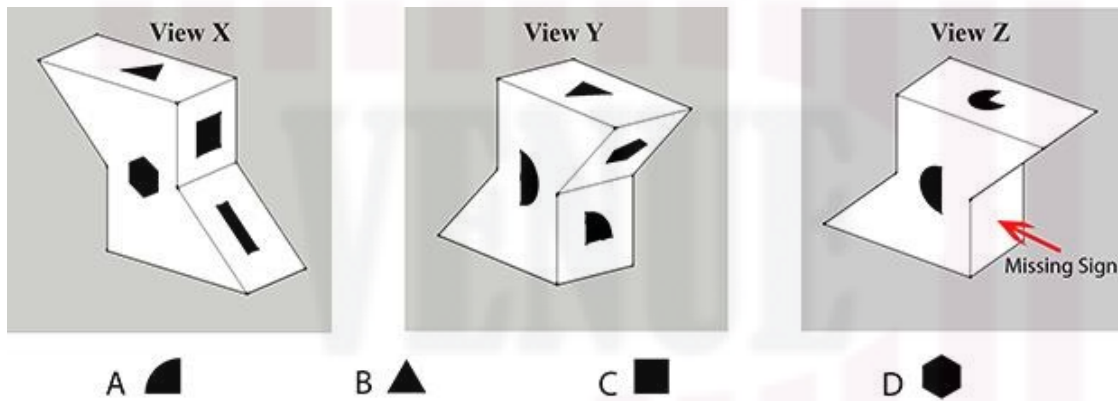

Q.30 A piece of paper is folded according to the sequence given below. After folding, cuts are made as per the shapes marked in yellow. Identify the resulting figure when the paper is unfolded fully.

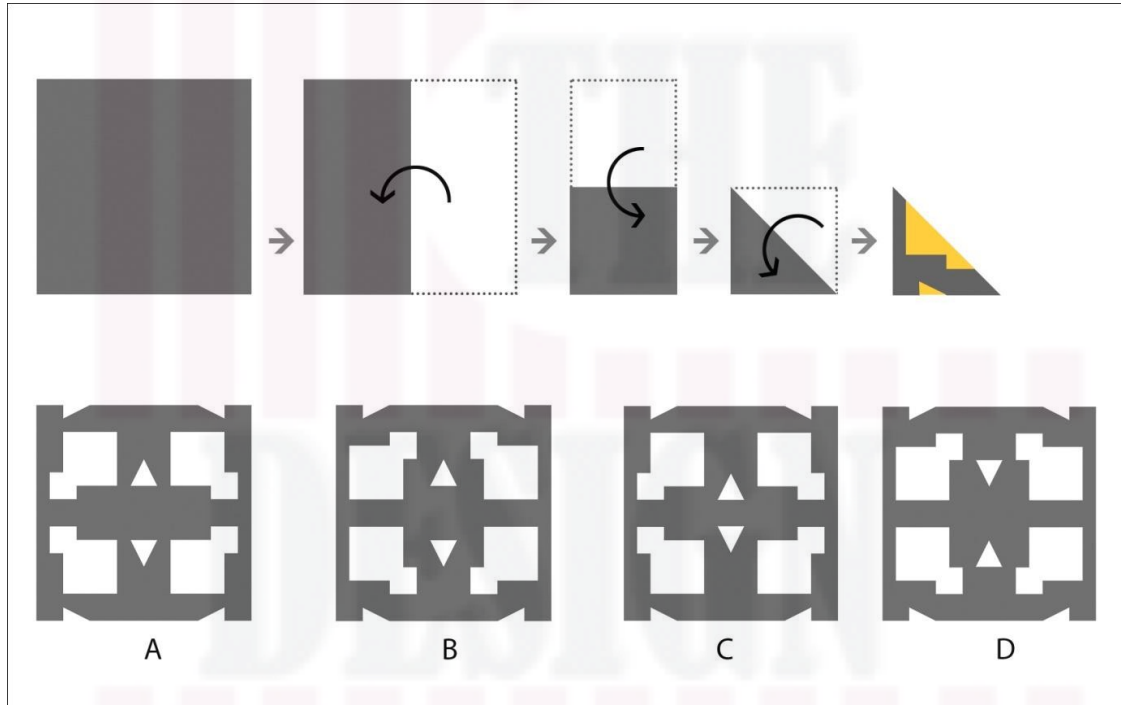

Q.31 Match the names of people who contributed to the following inventions.

1. Electric Lamp 2. Bicycle 3. Elevator 4. Movie Projector 5. Camera

- A. Thomas A Edison, Kirkpatrick Macmillan, Elisha G. Otis, Thomas A Edison, George Eastman
- B. Thomas A Edison, Rudolf Diesel, Elisha G. Otis, Lewis E. Waterman, George Eastman
- C. Lewis E. Waterman, Kirkpatrick Macmillan, Elisha G. Otis, Thomas A Edison, Chester Carlson
- D. Thomas A Edison, Rudolf Diesel, Elisha G. Otis, Chester Carlson, Lewis E. Waterman

32. In a well, there are two lizards, Red and Green. Both start climbing a slimy wall at the same time. In each attempt Green climbs three feet up and slides one foot down whereas Red climbs four feet up and slides two feet down. If the height of wall is 10 feet, who will reach the top of the wall in fewer attempts?

- A. None will reach the edge
- B. Green lizard
- C. Red lizard
- D. Red and Green lizards will take the same number of attempts



Q.33 Which one of the following paper pieces, when folded in to a cube, will have a continuous loop of red line?

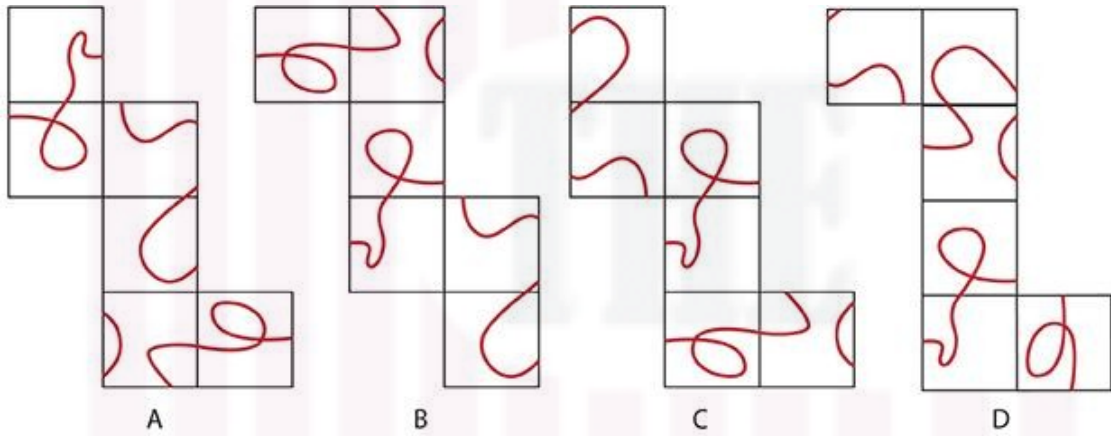

34. In a certain map, the southeast is wrongly marked as the north. As per the map, there is a school 100 m to the east of a temple and 100 m to the south of the temple is a playground. So, in reality, in which direction is the playground with respect to the school?

- A. North
- B. North – east
- C. South – west
- D. West

Q.35 In a mechanism hinged to the frame at point 'O' as shown in the figure, AB, CD, BG and GH are rigid members. These members are pivoted to each other at points B, G, D and O as shown in the figure. If you move the handles A and C from position 1a to 2a and 1c to 2c, respectively, identify the corresponding paths and positions of points G and H with respect to O.

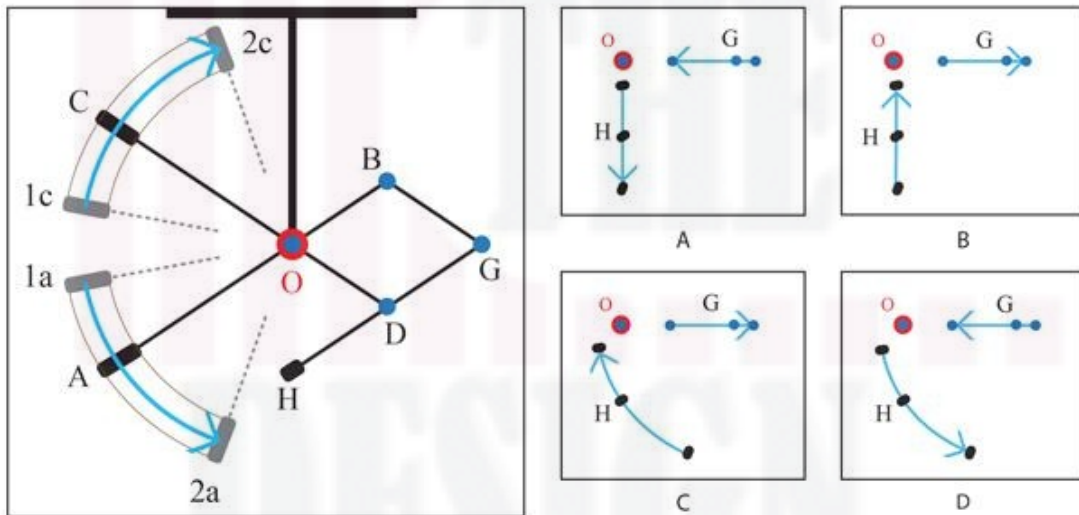

36. In the RGB (red-green-blue) colour system, the value for each colour component varies from 0 to 255. If the RGB values of a particular colour were R=255, G=140, B=0, then which colour is it?

- A. Orange
- B. Yellow
- C. Brown
- D. Grey

Q.37 Here is an illustration of Ravi and Anand celebrating with high fives. Their hands have not been included in the illustration. Choose the correct option for their hand positions.



Q.38 In the figure shown below, which option will replace the question mark?

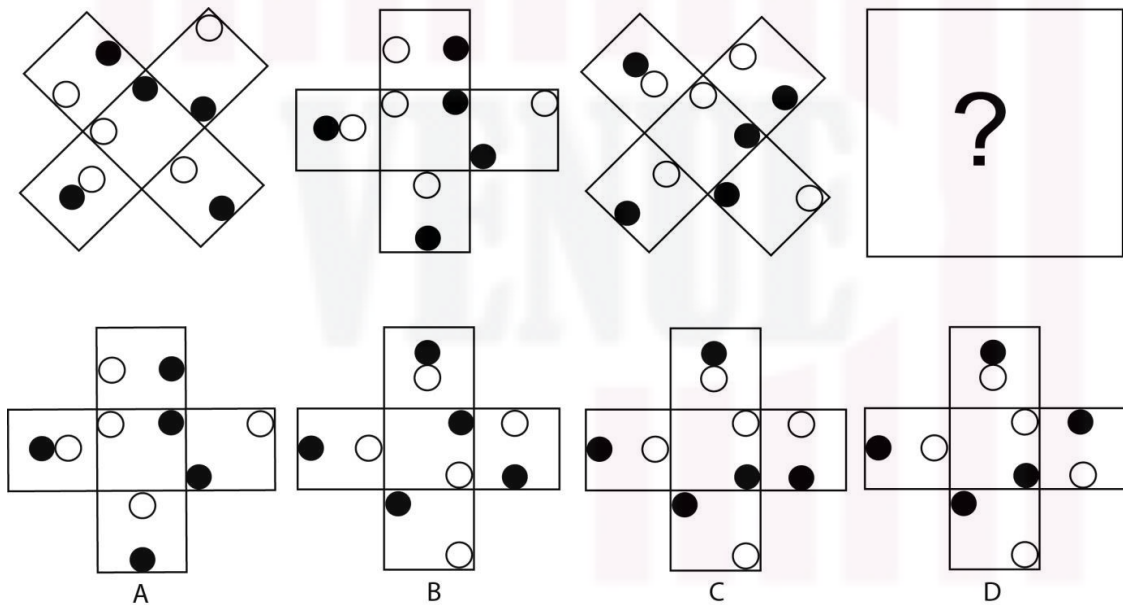

Q.39 Select the most appropriate option which matches the self portraits to artist's name.



1. Pablo Picasso
2. Paul Gauguin
3. Vincent Vangogh
4. Rembrandt

- A. P-1, Q-3, R-2, S-4
- B. P-3, Q-2, R-1, S-3
- C. P-2, Q-4, R-1, S-3
- D. P-4, Q-3, R-2, S-1

Q.40 Various cut out patterns are created from square shaped chart paper. If image S is the pattern created by overlapping three such patterns P, Q & R, then identify the missing pattern Q.

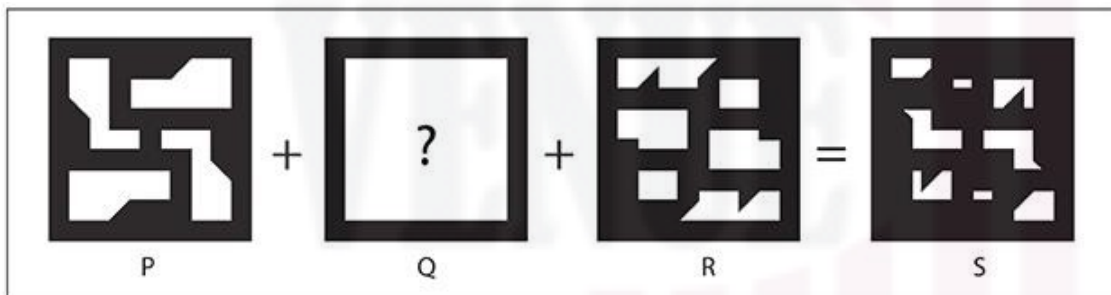

Q.41 If a film is projected at 90 feet per minute, how many frames will be present in one foot of film?

- A. 25 frames
- B. 24 frames
- C. 16 frames
- D. 30 frames

Q.42 “Fitts’s law” predicts nearer, wider targets are faster to select than farther, narrower targets. Shown below are parts of two Indian language virtual keyboards X and Y that demonstrate the input of a vowel modifier (*matra*) in Indian scripts. In each case, the first image shows the initial interface, and the second image shows the interface after the user touches a consonant. In both cases, the user selects the desired vowel modifier by sliding his finger towards it. Which of the statements below is TRUE, as per Fitts’s law?



- Users would select vowel modifiers on interface X in less time than on interface Y.
- Users would select vowel modifiers on interface Y in less time than on interface X.
- Users would select vowel modifiers on both interfaces in the same amount of time.
- Fitts’s law will have no effect on vowel modifier selection speeds.

43. A ball starts rolling down a slope as shown in the figure below. All units shown are in meters. The floor has very little friction. Which of the following is true after a long time?

- A. The ball will come to rest at P
- B. The ball will come to rest at Q
- C. The ball will come to rest at R
- D. The ball will continue to be in motion at point S

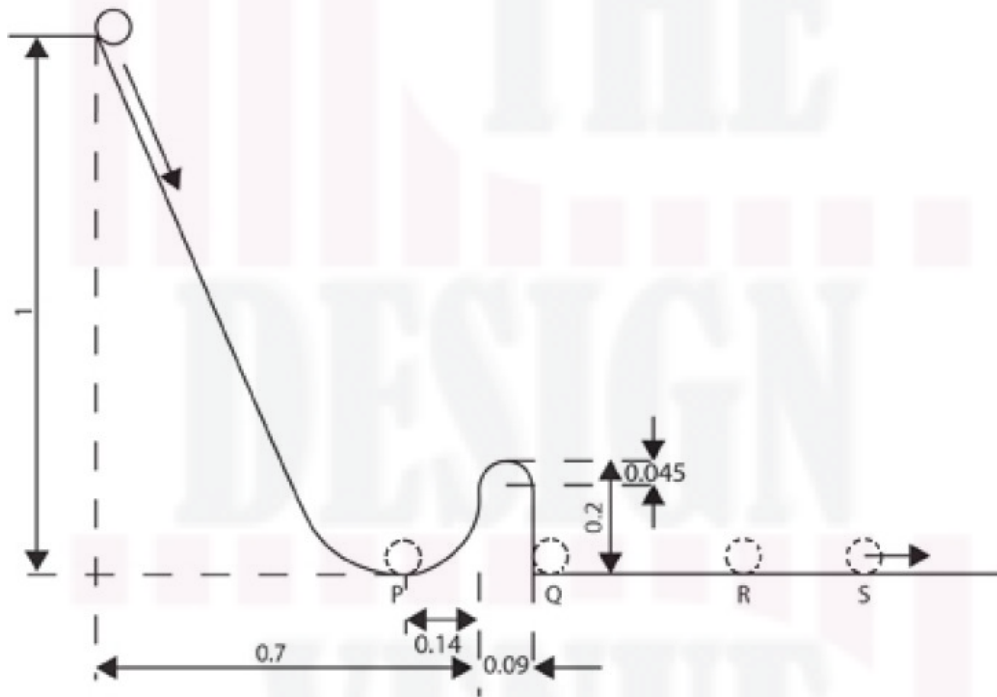

Q.44 The figure shown is an example of:

- A. Palindrome
- B. Ambigram
- C. Visindrome
- D. Inverdrome

*palindrome*

Q.45 Select the correct pair of camera angles for a scene with a series of opposing *over-the-shoulder* shots of the two subjects given below, such that subject **A** appears to the right and subject **B** appears to the left side of the frame.

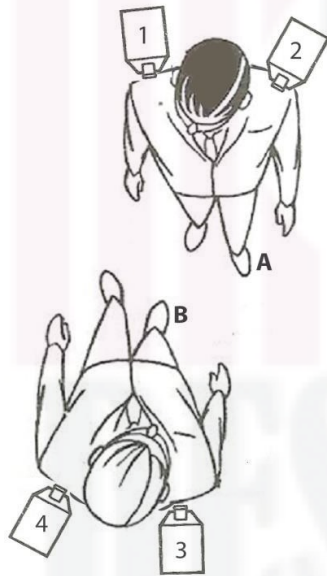

- A. 2 and 3
- B. 1 and 4
- C. 1 and 3
- D. 2 and 4



## Part B

Answer ANY ONE question out of 1, 2, 3, 4, and 5. (50 marks)

### Q.1 Industrial Design

You are provided with a base (chassis) of 100 cm x 75 cm as indicated below. It has:

- an inbuilt motor and battery-charger system
- capacity to carry maximum load of 200 kg (apart from its own weight)
- a maximum speed limit of 5km/hr

You are free to add other parts and accessories to it in order to make it a complete and stable product.

A. Using this platform, imagine and sketch 3 ideas for its use in a hospital environment.

B. Further, develop any one idea as a concept for actual implementation and:

- List down 10 critical factors you will consider in your design.
- Sketch and explain your concept for its functional details, features and usage.
- Suggest/indicate the materials and processes to manufacture the product.
- Write a brief note explaining the concept and list the design decisions taken.

**Evaluation criteria:** Critical thinking, identification of user needs and understanding of the context; problem solving and appropriateness of the solution; ability to explain details and features, sketching, presentation and articulation; knowledge of materials and processes.

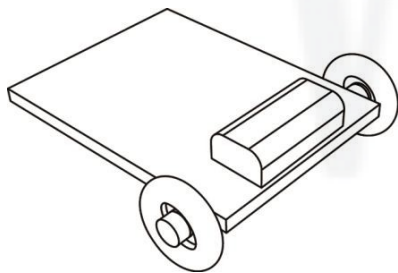

Answer ANY ONE question out of 1, 2, 3, 4, and 5. (50 marks)

## 2. Communication Design

Shaaradapur is an Indian village. It has a multi-lingual, low-literate population. There is a lack of awareness on maintaining health and hygiene. This results in an outbreak of malaria. Malaria is a mosquito-borne disease and its symptoms include fever, headache, vomiting and fatigue. If left untreated, malaria can be life threatening. So it is important that timely diagnosis and treatment are done under a trained medical practitioner at the government hospital in the village. Malaria can be prevented with mosquito control measures like draining stagnant water and spraying insecticides. Mosquito bites could also be avoided by using mosquito nets and insect repellents.

- Design a poster for villagers with the above information on malaria to be displayed prominently at a public place. This poster has to be specific to this village and should communicate (a) the seriousness, (b) the symptoms, (c) the actions to be taken and (d) the prevention of malaria.
- Select an ideal location in the village for this poster and
  - (a) Sketch to illustrate how it will be displayed at the location
  - (b) Write 5 sentences justifying your selection of the location, size and strategy in the way it is displayed.

**Evaluation Criteria:** Ability to understand the design brief, clarity of thought, articulation, creativity and presentation.

Answer ANY ONE question out of 1, 2, 3, 4, and 5. (50 marks)

### Q.3 Animation Design

An animation film for 5 to 12 year old children is in pre-production stage. The film is based on a 10 year old girl Priya and her cat. This is a shot breakdown of a sequence from the film.

**Shot 1** - It was such a bright and beautiful day that 10 year old Priya decided to play with her cat in the garden.

**Shot 2** - All of a sudden, the cat's attention is diverted by a little bird singing on a tree.

**Shot 3** - The cat quickly climbed up the tree and walked stealthily on the branch on which the bird is perched.

**Shot 4** - Priya anxiously watched from below.

**Shot 5** - As the cat approached the bird, the branch broke and the bird flew away.

**Shot 6** - Shocked, Priya quickly ran to catch the falling cat.

**Shot 7** - Priya tripped and fell.

**Shot 8** - Terrified, she looked up to see that the falling cat thankfully landed on its feet.

**Shot 9** - Priya picked up the cat and scolded her.

**Shot 10** - She then gave the cat a warm hug. The cat meowed back to her with a big smile.

Part 1

Illustrate (create a storyboard of) the above shots as a series of picture frames. You may use more than one frame per shot if you want to. Approximate shape of the frame is shown below.



**Evaluation criteria:** Communication of the narrative through sequential pictures, shot composition and perspective.

Part 2

Model Sheets – Design the characters Priya, the cat and the bird. Your drawings should depict the character so that it is a good reference for animation. It should also contain possible attitudes and expressions as may be needed by the film.

**Evaluation criteria:** Illustration skills and design of details in the character (keeping in mind that this will be used for animation). Your style can be realistic or stylised.

Answer ANY ONE question out of 1, 2, 3, 4, and 5. (50 marks)

#### Q.4 Interaction Design

Every day, around 500 people visit the city Regional Transport Office (RTO) for getting a driving licence. Some of these people are illiterate. The RTO is short on staff and struggles to cater to all these people. To get a licence the user needs to fill a form, take an objective-type test, and submit copies of age proof, address proof, a phone number, finger prints and a photograph. After verification of this, the user is issued a learner's licence. If the user has had a learner's licence for a month, he/she may apply for a permanent licence. In that case, the user is given a choice of a date for a driving test, after which the licence is issued.

The RTO has decided to put up an interactive public information system in the lobby of its office to ease the process. The primary target audiences for this system are:

1. Individuals who come to issue a learner's driving licence (typically 18–20 years old) and
2. Individuals who come to issue a permanent driving licence (typically 18–20 years old).

Based on this information, write in about 20 words the needs of different types of users and information that the system should provide. State the assumptions you are making about the availability of technology and information.

- Draw a sketch of the lobby to illustrate the physical location of the system and how users would interact with it.
- Present two scenarios (1) submission of application and (2) getting a licence to illustrate the details of the graphical interface and information flow. Each scenario should highlight specific problems the users might face and show how the system would solve these.

**Evaluation criteria:** Ability to understand the needs of users, originality, the logic and flow in the interface, usability and appropriateness of information, presentation.

Answer ANY ONE question out of 1, 2, 3, 4, and 5. (50 marks)

**Q.5 Mobility and Vehicle Design**

A company is planning to introduce an electric two-wheeler taxi in the city of Banaras (Varanasi) for local commuters and pilgrims. Design an electric two wheeler taxi by identifying at least five distinct and essential factors that will make it relevant for the city of Banaras in terms of function and aesthetics.

Present your design proposal as follows:

- Identify at least five distinct factors essential in designing such a solution.
- Draw a neat side elevation sketch of the proposed vehicle.
- Draw a neat freehand perspective sketch showing the overall form and its features.
- Indicate suitable materials used in manufacturing of the vehicle body.

**Evaluation criteria:** User-centric design considerations, form, feasibility and effectiveness of design solution, quality of sketch, originality and appropriateness of materials.

**6. Sketching question. Attempt ANY ONE of A or B. (20 marks)**

- Do not use any colours.
- Use only pencils.
- Do not use any drawing instruments such as ruler, compass, set-square etc.

A. Illustrate in perspective a still life composition with a plastic water bottle, a transparent half empty glass of water with a metal spoon inside it, a kitchen knife placed next to a half-eaten apple on a grey ceramic plate.

**Evaluation criteria:** Realistic drawing, proportions, quality of surface texture, shading, perspective and composition.

OR

B. Illustrate this scene. A dog chases a fruit seller carrying a basket full of bananas. A kid on a tricycle watches.

**Evaluation criteria:** Drawing, perspective, proportions and composition. Figures may be realistic or stylised.

**Q.7 Creativity (20 marks)**

A helmet is used to prevent head injury in risky situations. Helmets are used in many sports as well as while driving a bike. Describe five DIFFERENT creative ways you can use a helmet other than as a headgear. Sketch your ideas and write a one-line note to describe each idea.

**Evaluation Criteria:** Originality, imagination and presentation.

**Q.8 Stories (10 marks)**

Construct two different stories using the following three terms: Orphan, Mango, Cycle shop. Each story should not be longer than three sentences.

**Evaluation Criteria:** Originality and creativity of plots, ability to tell the story in only three sentences.